



DSX series

SAE AS81659
ARINC 404

	Page		Page
Introduction	6-4	DSX – ARINC 404 shell type B	
Applications	6-5	How to order	6-46
DSX – SAE AS81659		Technical characteristics :	6-47
Product overview	6-6	Materials	6-47
Technical characteristics :	6-7 & 6-8	Electrical	6-47
Electrical	6-7	Mechanical & Environmental	6-47
Mechanical & Environmental	6-7	Contact arrangements	6-48 & 6-49
Materials	6-8	Contacts :	6-50 to 6-53
Masses	6-8	Signal and power crimp contacts	6-50
How to order	6-9	Contacts with pc tail	6-50
Contact arrangement	6-10 to 6-12	Contacts with wire wrap post	6-51
Modification code	6-13 to 6-18	Solder cup contacts	6-51
Polarization code	6-19	Thermocouple contacts	6-51
Polarization code table	6-19 to 6-20	Fiber optic contacts	6-51
Contacts :	6-21 to 6-27	Coaxial crimp contacts	6-52 & 6-53
Signal and power contacts	6-21	Accessories	6-53
Thermocouple contacts	6-21	Dimensions	6-54 & 5-55
Contacts with pc tail	6-22	DSX – EMI/RFI	
Contacts with wire wrap post	6-23	Introduction	6-56
Coaxial crimp contacts	6-23 to 6-25	Part numbering	6-56
Concentric twinax crimp contact	6-26	Technical characteristics	6-56
Triax crimp contacts	6-26	Materials	6-56
Triax contact with pc tail	6-27	DSX – ARINC 404 shell type A	
Fiber optic contacts and accessories	6-28	Technical characteristics :	6-57
Accessories	6-29 to 6-30	Electrical	6-57
Dimensions	6-31 to 6-34	Mechanical & Environmental	6-57
Panel cut out	6-35	Materials	6-57
Cross reference	6-36 to 6-39	How to order	6-58
DSX – F		Contact arrangement	6-58
How to order	6-40	Modification code	6-59
Contacts :	6-41	Contacts	6-60
Contacts with pc tail	6-41	Accessories	6-60
Contacts with wire wrap post	6-41	Dimensions	6-60
Coaxial crimp contacts	6-41	Panel cut out	6-60
DSX – DATA BUS		Tools	6-61
How to order	6-42		
Technical characteristics	6-42		
Contact arrangement	6-43		
Dimensions	6-44 & 6-45		
Twinax contacts	6-45		

INTRODUCTION

The Radiall **DSX** rack and panel series are multipin rectangular connectors used to electrically interface avionics equipment to equipment rack. Usually the plug is installed on the avionic rack and the receptacle on the equipment box. The mated locking mechanism is provided for the equipment and cabinet and is not a part of the connector pair.

These connectors are widely used in applications such as:

- Commercial / military aircraft and helicopters,
- Radar systems,
- Power circuits,
- In-flight electronic instrumentation,
- Flight simulators, etc.....

The following versions are offered:

DSX - SAE AS81659: connectors conforming to SAE AS81659 including connectors listed on the QPL81659

DSX - ARINC 404 shell type B: connectors conforming to ARINC 404 shell type B - polarized shells

DSX - ARINC 404 shell type A: connectors conforming to ARINC 404 shell type A - single shell (without polarization)

DSX - F: connectors for front release front removable contacts (receptacle only)

DSX - DATA BUS: connectors for interconnection of multiplexed digital links

DSX - EMI/RFI: shielded connectors

DSX – SAE AS81659

These connectors fully conform to SAE AS81659 specifications and are listed the associated Qualified Product List. They are available in four shell sizes (1, 2, 3 and 4) which can respectively accept 1, 2, 3 and 4 inserts. Inserts are offered in various contact arrangements accommodating rear release rear removable signal (size 22), power (sizes 5, 12, 16 and 20HD), coaxial (sizes 1, 3, 5, 7, 9 and 15), concentric twinax (sizes 5 and 9), triax (sizes 5 and 9) contacts in crimp, wire wrap or PC tail termination. Radiall's 29504 fiber optic termini are also available. Both environmental and non environmental connectors are offered.

Mismating is prevented by a polarizing system which provides 216 polarizing positions. For military part numbers, applicable polarizing positions range goes from 00 through 99 only.

DSX – ARINC 404 shell type B

Arinc 404 shell type B are the commercial version. Here are the commercial features compared to the military version:

- They use both size 20HD and size 20 contacts.
- They are non environmental. Inserts are fitted with a rubber separator on their wiring rear face which does not provide sealing but provides wire protection.
- Removable size 5 and 9 coaxial contacts are not interchangeable with those of the military type.
- Insert retention plate is yellow anodized instead of blue anodized on the military version.

DSX – ARINC 404 shell type A

DSX - ARINC 404 shell type A connectors are only available in shell size 1. They use ARINC 404 shell type B inserts ; only one insert can be installed in the connector shell. Shell type A has no polarization system, mismating is prevented by keystone shaped shells. DSX ARINC 404 shell type A connectors cannot be fitted with any backshell.

DSX - F

DSX - F receptacle connectors are available in four shell sizes (1, 2, 3 and 4) and are designed to be fitted with front release front removable contacts offered in pc tail and wire wrap termination. Inserts are offered with or without an interfacial seal (in both cases they are not and are fitted with a separator) and are available in the following contact arrangements : 106, 67, 57, 45, 40, 33C4, 26.

DSX - F connectors are fully intermateable with connectors of the ARINC 404 shell type B and SAE AS81659 versions.

DSX - DATA BUS

These connectors have been designed to ensure the interconnection of multiplexed digital links used in military equipments.

DSX - EMI / RFI

In response to the continuing development of electronic systems used in ever harsher environments, these connectors have been designed to improve the shielding effectiveness against electromagnetic and radiofrequency interferences (EMI/RFI) as well as electromagnetic pulses (EMP).

APPLICATIONS

These connectors are used to form the electrical interface between avionics equipment to rack equipment.



©Eurocopter/photo Patrick PENNA



PRODUCT OVERVIEW

Detailed view of the various parts of this series connector.

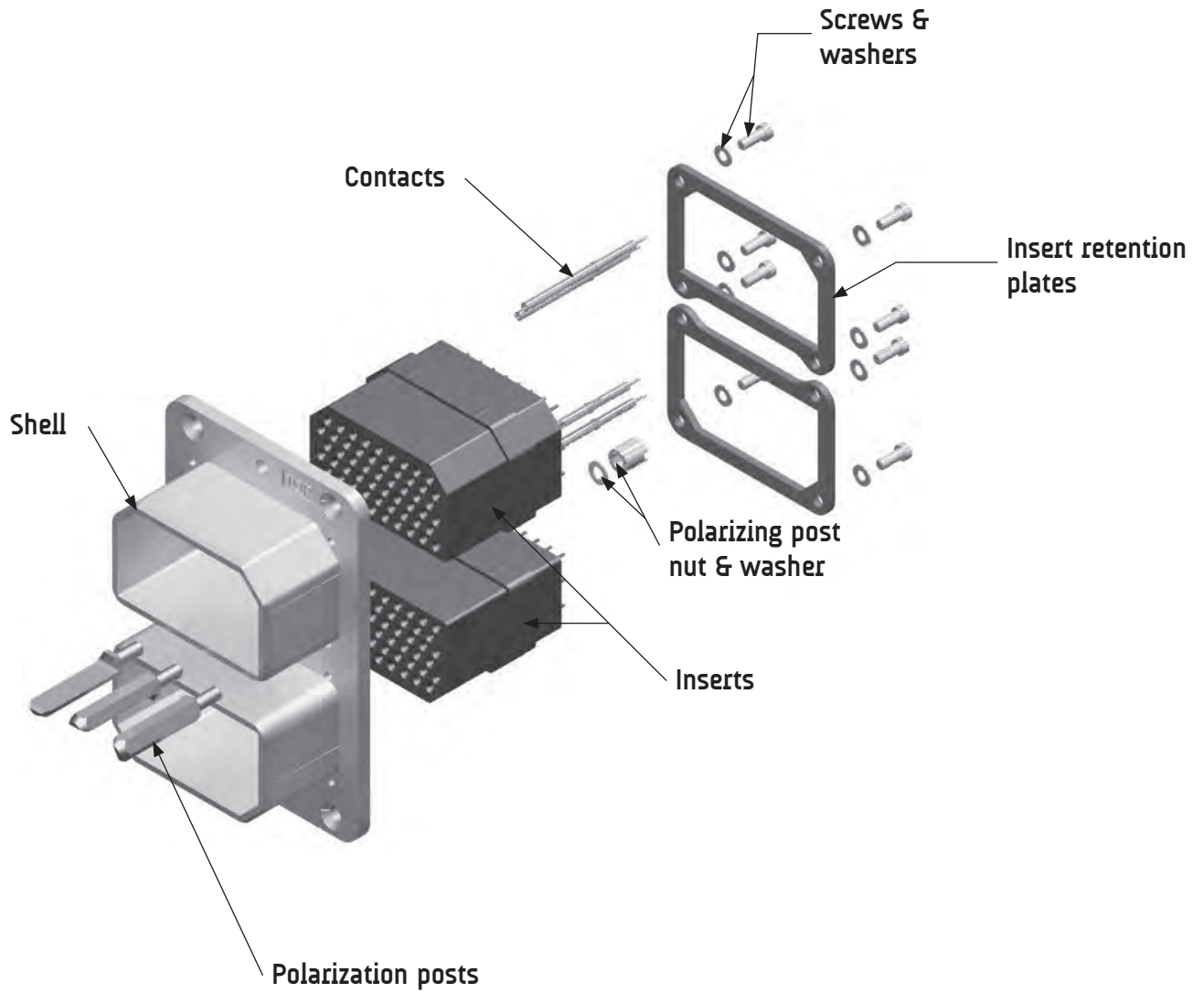

ELECTRICAL

Magnetic permeability: <2 μ

Insulation resistance: >5000 MΩ

Dielectric withstanding voltage: see contact arrangement on pages 6-10 to 6-12

Contact resistance: according to requirements of SAE AS39029.

Coax contacts electrical characteristics

Nominal impedance: 50 Ω

VSWR

- Sizes 5, 7 and 9: 1.3 from DC to 1500MHz
- Sizes 1 and 3: 1.3 from DC to 5000 MHz

Contact size	AWG	Cross section mm ² (sq.in)	Min. Outside dia. mm (inch)	Max. outside dia. mm (inch)	Max current (A)
22	22	0.38 (0.015)	0.76 (0.030)	1.4 (0.055)	5
	24	0.21 (0.008)			3
	26	0.14 (0.006)			2
20HD	20	0.60 (0.024)	1 (0.039)	1.8 (0.071)	7.5
	22	0.38 (0.015)			5
	24	0.21 (0.008)			3
16	16	1.34 (0.053)	1.70 (0.067)	2.6 (0.102)	13
	18	0.93 (0.037)			10
	20	0.60 (0.024)			7.5
12	12	3.18 (0.125)	2.4 (0.094)	3.4 (0.134)	23
	14	1.91 (0.075)			17
	16	1.34 (0.052)			13
For cavity 5	8	9.00 (0.354)	3.4 (0.134)	6.48 (0.255)	46
	10	5.00 (0.197)			33
	12	3.18 (0.125)			23
	14	1.91 (0.075)			17

MECHANICAL & ENVIRONMENTAL

Temperature range: -65°C (-85°F) / +125°C (+257°F)

Temperature life: 1000 hours at +125°C (+257°F)

Salt spray: EIA 364-26 (MIL-STD-1344A method 1001.1 test condition B (48 hours))

Altitude moisture injection: Insulation resistance > 100 M Ω altitude 50000 feet

Fluid resistance: resistance to 20 hours immersion in fluids MIL PRF 5606 & MIL PRF 23699

Durability: 500 matings & unmating cycles

Vibration: EIA 364-28 (MIL-STD-1344A method 2005 test condition IV (20g - 10-2000Hz))

Shock: EIA 364-27 (MIL-STD-1344A method 2004 test condition A (50g -11ms - half sine))

Mating force: < 200N (45 lbs) per insert

Insert retention force: > 534N (120 lbs) in each direction

Contact retention force: max axial displacement = 0.3mm (0.012 inches)

Contact size	22	20HD	16	12
Axial load N (lbs)	66N (15)	89N (20)	111N (25)	133.5N (30)

TECHNICAL CHARACTERISTICS

MATERIALS

Description	Material	Plating
Shell	Aluminium alloy	Cadmium yellow chromate*
Insert	Thermosetting resin	/
Metallic insert	Aluminium alloy	Cadmium clear chromate*
Interfacial seal & grommet	Silicone rubber	/
Retention clip	Copper alloy	/
Contact	Copper alloy	Gold over nickel under plate
Insert retention plate	Aluminium alloy	Blue anodised*
Polarizing posts	Stainless steel	/
Polarizing keys	Zinc alloy	Cadmium yellow chromate
Polarizing keys retention plate	Aluminium alloy	Cadmium yellow chromate*
Screws, washers, clinch-nuts	Corrosion resistant steel	/
Sealing plugs and filler plugs	PTFE	/
Sealing boots and sleeves	Fluorinated silicon rubber	/
Sealing bushing	PEI	/
Junction shells	Aluminium alloy	Yellow anodized or nickel plated

* More platings are available, see descriptions in modification codes

MASSES (estimates)

Description	Weight g (oz)
Plug shell size 1	30 (1.05)
Plug shell size 2	45 (1.60)
Plug shell size 3	60 (2.15)
Plug shell size 4	85 (3)
Receptacle shell 1	30 (1.05)
Receptacle shell 2	50 (1.75)
Receptacle shell 3	85 (3)
Receptacle shell 4	115 (4.05)
Plastic insert	20 (0.70)
Metallic insert	35 (1.25)
Junction shells	25 (0.88)

HOW TO ORDER CONNECTORS

DSX series

DSX	N	4	P	G	S	40	S	S8S	S26S	S45P	00	01
-----	---	---	---	---	---	----	---	-----	------	------	----	----

Series _____

Class _____
N: Non environmental (without grommet and interfacial seal)
E: Environmental (with grommet and interfacial seal)
T: Connector with interfacial seal on insert with protruding contacts only

Shell size _____
1 : One gang shell
2 : Two gang shell
3 : Three gang shell
4 : Four gang shell

Shell type _____
R : Receptacle
P : Plug

Grounding EMI/RFI _____
G: with grounding spring (only for plug connector)

Termination style _____
X : Without contacts (for crimp contacts only)
S : Crimp ^(See note 1)
V : Wire wrap two levels ⁽⁴⁾
W : Wire wrap three levels ⁽⁴⁾
Y : PC tail contact ⁽⁴⁾

Contact arrangement ^(See note 2) _____
 See available contact arrangements on pages 6-10 to 6-12

Contact type _____
S : Socket
P : Pin

Gang B _____

Gang C _____

Gang D _____

Modification code _____
 See pages 6-13 to 6-19 for selection
 Modification code will help in choosing the appropriate plating for your application.

Polarization code ^(See note 3) _____
 See pages 6-20 to 6-21 for selection













Gang A

Important note: If you want to get connectors marked with the military part number (i.e. M81659/66A2-0083) you must order by using the military part number. Radiall part numbers qualified to SAE AS81659 versus military part numbers are listed from pages 6-36 to 6-39.











- NOTES:**
- (1) If you need to use reduced crimp barrel, thermocouple or fiber optic contacts, use code X and order contact separately.
 - (2) For MC2, MC3 and C8 contact arrangements which include coax contacts, use termination code X and order coax contacts separately.
 - (3) Without polarization code the connector is delivered with the polarizing system unassembled. With polarization code 00: the connector is delivered without polarizing system. With polarization code from 01 to 216: the connector is delivered with polarization hardware assembled as defined by code. Polarization codes for connector qualified to SAE AS81659 are ranging from 00 to 99 only.
 - (4) PC tail and wire wrap contacts are delivered installed. For 67, 32C4 and 33C4 contact arrangements, size 16 contacts are delivered not installed and in crimp termination.

CONTACT ARRANGEMENTS

pin insert mating side shown





Insert name	Number of contacts	Dielectric Withstanding Voltage (DWV)	Insert name	Number of contacts	DWV
C5 ^(See note 1)	 5 x #5 (power)	2500V - 60Hz This insert is available in class N only.	57 ^(See note 1)	 57 x #20HD	1500v - 60Hz
8	 8 x #12	1500V - 60Hz	67	 64 x #20HD 3 x #16	21000V - 60Hz
D8	 4 x #16 4 x #12	1500V - 60Hz	106	 106 x #22	1000V - 60Hz
26	 26 x #16	1500V - 60Hz	40C1	 1 x #5 (coax) 39 x #20HD	1500V - 60Hz
40	 40 x #20HD	1500V - 60Hz	40T1 ^(See note 1)	 1 x #5 (coax) 39 x #20HD	1500V - 60Hz Size 5 contact cavity grounded to the shell
45	 45 x #20HD	1500V - 60Hz	32C2	 2 x #5 (coax) 39 x #20HD	1000V - 60Hz

CONTACT ARRANGEMENTS pin insert mating side shown

Insert name	Number of contacts	DWV	Insert name	Number of contacts	DWV
32T2 ^(See note 1)	 2 x #5 (coax) 30 x #20HD	1000V – 60Hz Size 5 contact cavities grounded to the shell	36C7 ^(See note 1)	 7 x #5 (coax) 29 x #22	1000V – 60Hz
32C4	 4 x #9 (coax) 4 x #16 24 x #20HD	1500V – 60Hz	36T7 ^(See note 1)	 7 x #5 (coax) 29 x #22	1000V – 60Hz Size 5 contact cavities grounded to the shell
32T4 ^(See note 1)	 4 x #9 (coax) 4 x #16 24 x #20HD	1500V – 60Hz Size 9 contact cavities grounded to the shell	MC2	 2 x #1 (coax)	This insert is metallic
33C4	 4 x #5 (coax) 4 x #16 25 x #20HD	1000V – 60Hz	MC3	 2 x #7 (coax) 1 x #3 (coax)	This insert is metallic
33T4 ^(See note 1)	 4 x #5 (coax) 4 x #16 25 x #20HD	1000V – 60Hz Size 5 contact cavities grounded to the shell	C8	 7 x #9 (coax)	1000V – 60Hz







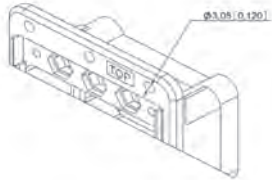

NOTE:
(1) Contact arrangements are not referenced in the MS3157 and SAE AS81659 standards.

CONTACT ARRANGEMENTS pin insert mating side shown

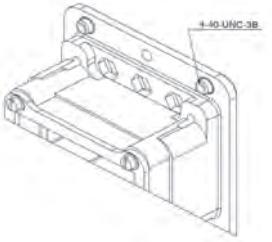
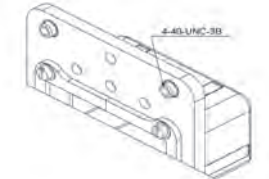
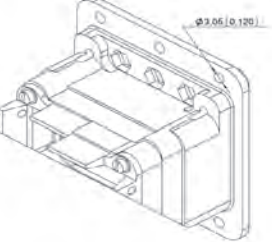

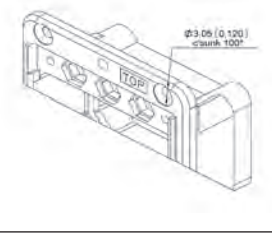

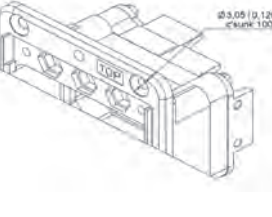
Insert name	Number of contacts	DWV
<p>T8*</p>  <p>8 x #9 (coax)</p>		<p>Size 9 contact cavities grounded to the shell. Pin contact available only</p>
<p>6CU</p>  <p>6 x #8 Quadrax</p>		<p>Size 8 contact cavities grounded to the shell. Non environmental only</p>
<p>81C3</p>  <p>78 x # 22 3 x #5 (coax)</p>		<p>1000V - 60Hz</p>
<p>00*</p> 		<p>Dummy insert-</p>



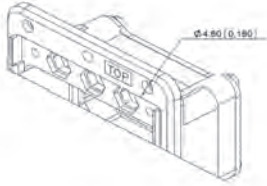

Connectors can be front or rear mount.

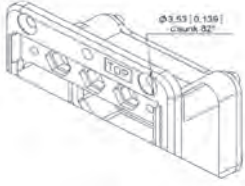
It should be noted that there is only 4mm between the connector flanges when fully mated. Then, modification code and screw types shall be selected according to this constraint.

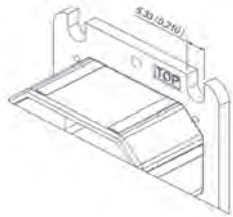
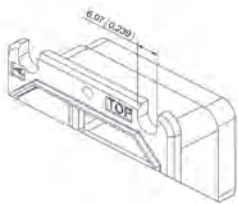
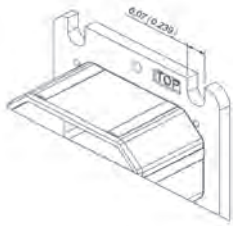
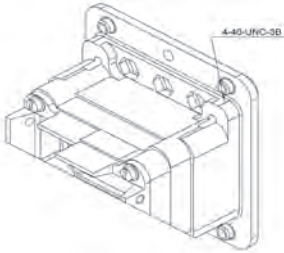
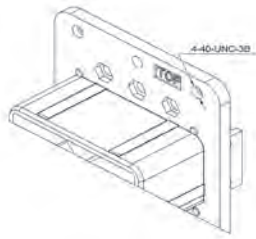
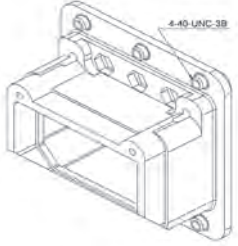
CODE	Receptacle shell		Plug shell	
00		Sizes 1 & 2: 6 holes Ø3,05 (0.120) Size 4: 10 holes Ø3,05 (0.120)		Sizes 1 & 2: 4 holes Ø3,05 (0.120) c'sunk 90° Size 3: 6 holes Ø3,05 (0.120) c'sunk 90° Size 4: 10 holes Ø3,05 (0.120) c'sunk 90°
01		Sizes 1 & 2: 4 clinch nuts 4.40 UNC 3B Size 3 : 6 clinch nuts 4.40 UNC 3B Size 4 : 10 clinch nuts 4.40 UNC 3B		Sizes 1 & 2: 4 clinch nuts 4,40 UNC 3B Size 3 : 6 clinch nuts 4.40 UNC 3B Size 4 : 10 clinch nuts 4.40 UNC 3B
02		Sizes 1, 2 & 3: 6 holes Ø3,05 (0.120) with attaching tabs for RADIALL backshell Not Available in Size 4		Sizes 1 & 2: 4 holes Ø3,05 (0.120) c'sunk 90° with attaching tabs for RADIALL backshell Size 3: 6 holes Ø3,05 (0.120) c'sunk 90° with attaching tabs for RADIALL backshell Not Available in Size 4
03		Sizes 1 & 2: 4 holes Ø3,05(0.120) c'sunk 100° Size 3: 6 holes Ø3,05(0.120) c'sunk 100° Size 4: 10 holes Ø3,05(0.120) c'sunk 100°		Sizes 1 & 2: 4 holes Ø3,05(0.120) c'sunk 100° Size 3: 6 holes Ø3,05(0.120) c'sunk 100° Size 4: 10 holes Ø3,05(0.120) c'sunk 100°
04		Sizes 1 & 2: 4 holes Ø3,05(0.120) c'sunk 100° with attaching tabs for RADIALL backshell Size 3: 6 holes Ø3,05(0.120) c'sunk 100° with attaching tabs for RADIALL backshell Not Available in Size 4		Sizes 1 & 2: 4 holes Ø3,05(0.120) c'sunk 100° with attaching tabs for RADIALL backshell Size 3: 6 holes Ø3,05(0.120) c'sunk 100° with attaching tabs for RADIALL backshell Not Available in Size 4

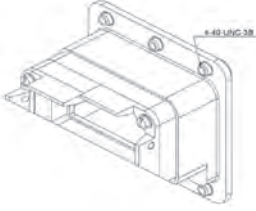
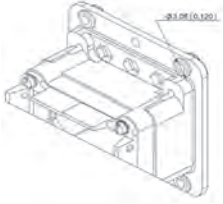

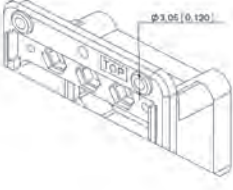

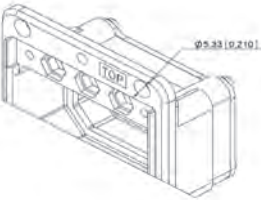
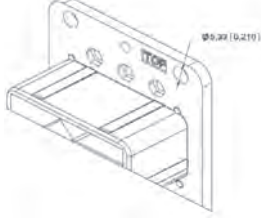
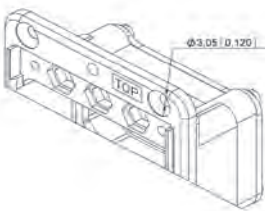
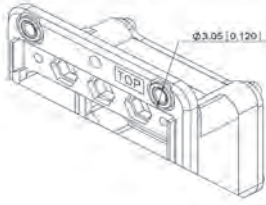
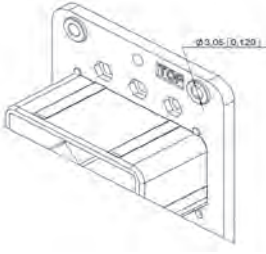

MODIFICATION CODE

CODE	Receptacle shell		Plug shell	
05		<p>Sizes 1,2 & 3: 4 holes Ø4,80 (0.189) Size 4: 10 holes Ø4,80 (0.189)</p>		<p>Sizes 1,2 & 3: 4 holes Ø4,80 (0.189) Size 4: 10 holes Ø 4,80 (0.189)</p>
08		<p>Sizes 1 & 2: 4 holes Ø3,53 (0.139) c'sunk 82° Size 3: 6 holes Ø3,53 (0.139) c'sunk 82°</p>		<p>Sizes 1 & 2: 4 holes Ø3,53 (0.139) c'sunk 82° Size 3: 6 holes Ø3,53 (0.139) c'sunk 82°</p>
12	--	--		<p>Sizes 1, 2 & 3: 4 mounting slots 5,33 (0.210) wide</p>
13		<p>Sizes 1, 2 & 3: 4 mounting slots 6,07 (0.239) wide</p>		<p>Sizes 1, 2 & 3: 4 mounting slots 6,07 (0.239) wide</p>
17		<p>Sizes 1 & 2: 4 clinch nuts 4.40 UNC 3B with attaching tabs for RADIALL backshell Size 3: 6 clinch nuts 4.40 UNC 3B with attaching tabs for RADIALL backshell Not Available in Size 4</p>		<p>Sizes 1 & 2 : 4 clinch nuts 4.40 UNC 3B with attaching tabs for RADIALL backshell Size 3: 6 clinch nuts 4.40 UNC 3B with attaching tabs for RADIALL backshell Not available in size 4</p>
18		<p>Sizes 1, 2 & 3: 6 clinch nuts 4.40 UNC 3B Not Available in Size 4</p>	--	--

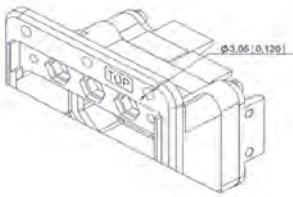

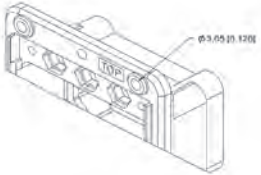
CODE	Receptacle shell		Plug shell	
19		<p>Sizes 1, 2 & 3: 6 clinch nuts 4,40 UNC 3B with attaching tabs for RADIALL backshell</p> <p>Not Available in Size 4</p>	--	--
22		<p>Sizes 1 & 2: 4 floating eyelets Ø3,05 (0.120) with attaching tabs for RADIALL backshell</p> <p>Size 3: 6 floating eyelets Ø3,05 (0.120) with attaching tabs for RADIALL backshell</p> <p>Not Available in Size 4</p>		<p>Sizes 1 & 2: 4 floating eyelets Ø3,05 (0.120) with attaching tabs for RADIALL backshell</p> <p>Size 3: 6 floating eyelets Ø3,05 (0.120) with attaching tabs for RADIALL backshell</p> <p>Not Available in Size 4</p>
23		<p>Sizes 1 & 2: 4 floating eyelets Ø3,05 (0.120)</p> <p>Size 3: 6 floating eyelets Ø3,05 (0.120)</p> <p>Size 4: 10 floating eyelets Ø3,05 (0.120)</p>		<p>Sizes 1 & 2: 4 floating eyelets Ø3,05 (0.120)</p> <p>Size 3: 6 floating eyelets Ø3,05 (0.120)</p> <p>Size 4: 10 floating eyelets Ø3,05 (0.120)</p>
24		<p>Sizes 1, 2 & 3: 6 holes Ø5,33 (0.210)</p>		<p>Sizes 1, 2 & 3: 6 holes Ø5,33 (0.210)</p>
26		<p>Sizes 1 & 2: 4 holes Ø3,05(0.120) c'sunk 90°</p> <p>Size 3: 6 holes Ø3,05(0.120) c'sunk 90°</p> <p>Size 4: 10 holes Ø 3,05(0.120) c'sunk 90°</p>	--	--
33		<p>Sizes 1 & 2: 4 flush front embedded floating eyelets Ø3,05 (0.120)</p> <p>Size 3: 6 flush front embedded floating eyelets Ø3,05 (0.120)</p> <p>Size 4: 10 flush front embedded floating eyelets Ø3,05 (0.120)</p>		<p>Sizes 1 & 2: 4 flush rear embedded floating eyelets Ø3,05 (0.120)</p> <p>Size 3: 6 flush rear embedded floating eyelets Ø3,05 (0.120)</p> <p>Size 4: 10 flush rear embedded floating eyelets Ø3,05 (0.120)</p>

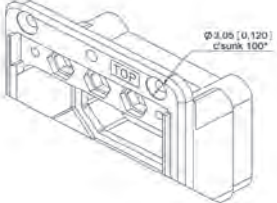
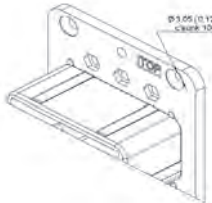
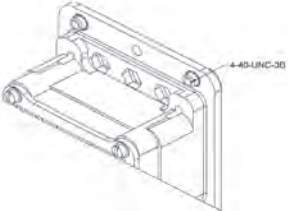
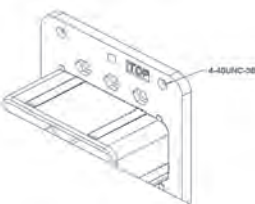
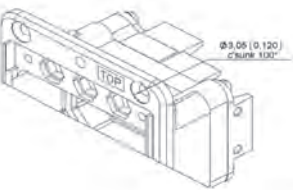
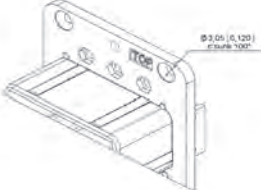
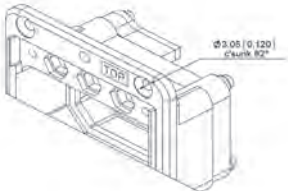
MODIFICATION CODE

CODE	Receptacle shell		Plug shell	
34		<p>Sizes 1 & 2: 4 flush rear embedded floating eyelets Ø3,05 (0,120)</p> <p>Size 3: 6 flush rear embedded floating eyelets Ø3,05 (0,120)</p> <p>Size 4: 10 flush rear embedded floating eyelets Ø3,05 (0,120)</p>		<p>Sizes 1 & 2: 4 flush front embedded floating eyelets Ø3,05 (0,120)</p> <p>Size 3: 6 flush front embedded floating eyelets Ø3,05 (0,120)</p> <p>Size 4: 10 flush front embedded floating eyelets Ø3,05 (0,120)</p>
35		<p>Sizes 1 & 2: 4 flush front embedded floating eyelets M2.5 threaded</p> <p>Size 3: 6 flush rear embedded floating eyelets M2.5 threaded</p>		<p>Sizes 1 & 2: 4 flush rear embedded floating eyelets M2.5 threaded</p> <p>Size 3: 6 flush rear embedded floating eyelets M2.5 threaded</p>
36		<p>Sizes 1 & 2: 4 flush front embedded floating eyelets M2.5 threaded with attaching tabs for RADIALL backshell</p> <p>Size 3: 6 flush front embedded floating eyelets M2.5 threaded with attaching tabs for RADIALL backshell</p> <p>Not Available in size 4</p>		<p>Sizes 1 & 2: 4 flush front embedded floating eyelets M2.5 threaded with attaching tabs for RADIALL backshell</p> <p>Size 3: 6 flush front embedded floating eyelets M2.5 threaded with attaching tabs for RADIALL backshell</p> <p>Not Available in size 4</p>
55	--	--		<p>Sizes 1, 2 & 3: Spring loaded shell 6 places</p>
60		Similar to modification code 00 except that the shell, keys and keys retention plate are nickel plated.		Similar to modification code 00 except that the shell, keys and keys retention plate are nickel plated.
61		Similar to modification code 22 except that the shell, keys and keys retention plate are nickel plated. Not available in size 4		Similar to modification code 22 except that the shell, keys and keys retention plate are nickel plated. Not available in size 4

CODE	Receptacle shell	Plug shell
62	 <p>Similar to modification code 02 except that the shell, keys and keys retention plate are nickel plated.</p> <p>Not available in size 4</p>	 <p>Similar to modification code 02 except that the shell, keys and keys retention plate are nickel plated.</p> <p>Not available in size 4</p>
63	 <p>Similar to modification code 23 except that the shell, keys and keys retention plate are nickel plated.</p>	 <p>Similar to modification code 23 except that the shell, keys and keys retention plate are nickel plated.</p>
64	 <p>Similar to modification code 03 except that the shell, keys and keys retention plate are nickel plated.</p>	 <p>Similar to modification code 03 except that the shell, keys and keys retention plate are nickel plated.</p>
66	 <p>Similar to modification code 01 except that the shell, keys and keys retention plate are nickel plated.</p>	 <p>Similar to modification code 01 except that the shell, keys and keys retention plate are nickel plated.</p>
67	 <p>Sizes 1 & 2: 4 holes $\varnothing 3,05$ (0.120) c'sunk 100° with attaching tabs for RADIALL backshell Size 3: 6 holes $\varnothing 3,05$ (0.120) c'sunk 100° with attaching tabs for RADIALL backshell Shells are nickel plated. Not Available in size 4</p>	 <p>Sizes 1 & 2: 4 holes $\varnothing 3,05$ (0.120) c'sunk 100° with attaching tabs for RADIALL backshell Size 3: 6 holes $\varnothing 3,05$ (0.120) c'sunk 100° with attaching tabs for RADIALL backshell. Shells are nickel plated Not Available for Size 4</p>
73	 <p>Sizes 1 & 2: 4 holes $\varnothing 3,05$ (0.120) c'sunk 82° Size 3: 6 holes $\varnothing 3,05$ (0.120) c'sunk 82° Size 4: 10 holes $\varnothing 3,05$ (0.120) c'sunk 82°</p>	 <p>Sizes 1 & 2: 4 holes $\varnothing 3,05$ (0.120) c'sunk 82° Size 3: 6 holes $\varnothing 3,05$ (0.120) c'sunk 82° Size 4: 10 holes $\varnothing 3,05$ (0.120) c'sunk 82°</p>

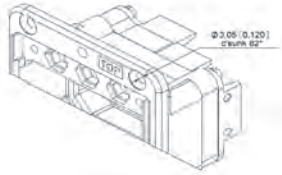
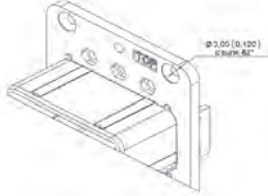
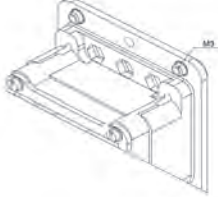
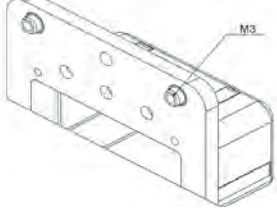
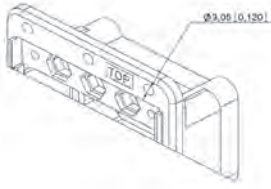
MODIFICATION CODE

CODE	Receptacle shell		Plug shell	
77		<p>Sizes 1 & 2: 4 holes Ø3,05 (0.120) c'sunk 82° with attaching tabs for RADIALL backshell</p> <p>Size 3: 6 holes Ø3,05 (0.120) c'sunk 82° with attaching tabs for RADIALL backshell</p> <p>Not Available for Size 4</p>		<p>Sizes 1 & 2: 4 holes Ø3,05 (0.120) c'sunk 82° with attaching tabs for RADIALL backshell</p> <p>Size 3: 6 holes Ø3,05 (0.120) c'sunk 82° with attaching tabs for RADIALL backshell</p> <p>Not Available for Size 4</p>
79		<p>Sizes 1 & 2: 4 M3 clinch nuts</p> <p>Size 3: 6 M3 clinch nuts</p> <p>Size 4: 10 M3 clinch nuts</p>		<p>Sizes 1 & 2: 4 M3 clinch nuts</p> <p>Size 3: 6 M3 clinch nuts</p> <p>Size 4: 10 M3 clinch nuts</p>
90		<p>Sizes 1 & 2: 4 flush rear embedded floating eyelets Ø3,05 (0.120)</p> <p>Size 3: 6 flush rear embedded floating eyelets Ø3,05 (0.120)</p> <p>Size 4: 10 flush rear embedded floating eyelets Ø3,05 (0.120)</p>		<p>Sizes 1 & 2: 4 holes Ø3,05 (0.120) c'sunk 90° with attaching tabs for RADIALL backshell</p> <p>Size 3: 6 holes Ø3,05 (0.120) c'sunk 90° with attaching tabs for RADIALL backshell</p> <p>Not Available for Size 4</p>

POLARIZATION CODE

Position of polarization keys and posts.
Connectors are shown front side, with "TOP" upwards.

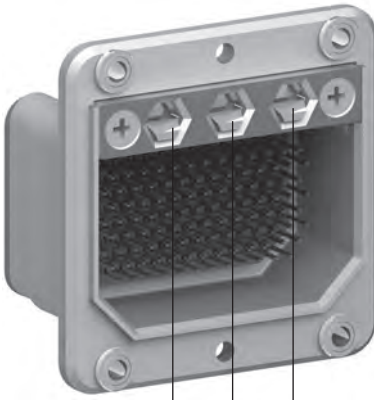

Left Key

Center Key

Right Key

Right Polarizing Post

Center Polarizing Post

Left Polarizing Post

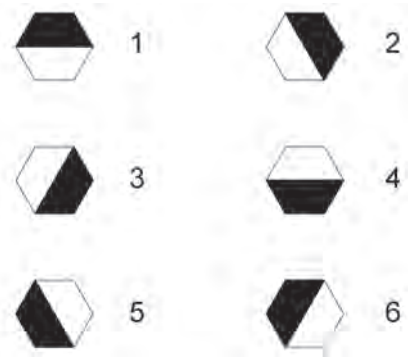

Position coding

Dark area represents the polarizing post.
Clear position represents the key hole.

POLARIZATION CODE TABLE

Polarization code	Receptacle shell			Plug shell		
	Left key	Center key	Right key	Left post	Center post	Right post
00	/	/	/	/	/	/
01	4	4	4	1	1	1
02	4	4	3	2	1	1
03	4	4	2	3	1	1
04	4	4	1	4	1	1
05	4	4	6	5	1	1
06	4	4	5	6	1	1
07	5	4	4	1	1	6
08	5	4	3	2	1	6
09	5	4	2	3	1	6
10	5	4	1	4	1	6
11	5	4	6	5	1	6
12	5	4	5	6	1	6
13	6	4	4	1	1	5
14	6	4	3	2	1	5
15	6	4	2	3	1	5
16	6	4	1	4	1	5
17	6	4	6	5	1	5
18	6	4	5	6	1	5
19	1	4	4	1	1	4
20	1	4	3	2	1	4
21	1	4	2	3	1	4
22	1	4	1	4	1	4
23	1	4	6	5	1	4
24	1	4	5	6	1	4
25	2	4	4	1	1	3
26	2	4	3	2	1	3
27	2	4	2	3	1	3
28	2	4	1	4	1	3

Polarization code	Receptacle shell			Plug shell		
	Left key	Center key	Right key	Left post	Center post	Right post
29	2	4	6	5	1	3
30	2	4	5	6	1	3
31	3	4	4	1	1	2
32	3	4	3	2	1	2
33	3	4	2	3	1	2
34	3	4	1	4	1	2
35	3	4	6	5	1	2
36	3	4	5	6	1	2
37	4	3	4	1	2	1
38	4	3	3	2	2	1
39	4	3	2	3	2	1
40	4	3	1	4	2	1
41	4	3	6	5	2	1
42	4	3	5	6	2	1
43	5	3	4	1	2	6
44	5	3	3	2	2	6
45	5	3	2	3	2	6
46	5	3	1	4	2	6
47	5	3	6	5	2	6
48	5	3	5	6	2	6
49	6	3	4	1	2	5
50	6	3	3	2	2	5
51	6	3	2	3	2	5
52	6	3	1	4	2	5
53	6	3	6	5	2	5
54	6	3	5	6	2	5
55	1	3	4	1	2	4
56	1	3	3	2	2	4
57	1	3	2	3	2	4

Polarization code	Receptacle shell			Plug shell		
	Left key	Center key	Right key	Left post	Center post	Right post
58	1	3	1	4	2	4
59	1	3	6	5	2	4
60	1	3	5	6	2	4
61	2	3	4	1	2	3
62	2	3	3	2	2	3
63	2	3	2	3	2	3
64	2	3	1	4	2	3
65	2	3	6	5	2	3
66	2	3	5	6	2	3
67	3	3	4	1	2	2
68	3	3	3	2	2	2
69	3	3	2	3	2	2
70	3	3	1	4	2	2
71	3	3	6	5	2	2
72	3	3	5	6	2	2
73	4	2	4	1	3	1
74	4	2	3	2	3	1
75	4	2	2	3	3	1
76	4	2	1	4	3	1
77	4	2	6	5	3	1
78	4	2	5	6	3	1
79	5	2	4	1	3	6
80	5	2	3	2	3	6
81	5	2	2	3	3	6
82	5	2	1	4	3	6
83	5	2	6	5	3	6
84	5	2	5	6	3	6
85	6	2	4	1	3	5
86	6	2	3	2	3	5
87	6	2	2	3	3	5
88	6	2	1	4	3	5
89	6	2	6	5	3	5
90	6	2	5	6	3	5
91	1	2	4	1	3	4
92	1	2	3	2	3	4
93	1	2	2	3	3	4
94	1	2	1	4	3	4
95	1	2	6	5	3	4
96	1	2	5	6	3	4
97	2	2	4	1	3	3
98	2	2	3	2	3	3
99	2	2	2	3	3	3
100	2	2	1	4	3	3
101	2	2	6	5	3	3
102	2	2	5	6	3	3
103	3	2	4	1	3	2
104	3	2	3	2	3	2
105	3	2	2	3	3	2
106	3	2	1	4	3	2
107	3	2	6	5	3	2
108	3	2	5	6	3	2
109	4	1	4	1	4	1
110	4	1	3	2	4	1
111	4	1	2	3	4	1
112	4	1	1	4	4	1
113	4	1	6	5	4	1
114	4	1	5	6	4	1
115	5	1	4	1	4	6
116	5	1	3	2	4	6
117	5	1	2	3	4	6
118	5	1	1	4	4	6
119	5	1	6	5	4	6
120	5	1	5	6	4	6
121	6	1	4	1	4	5
122	6	1	3	2	4	5
123	6	1	2	3	4	5
124	6	1	1	4	4	5
125	6	1	6	5	4	5
126	6	1	5	6	4	5
127	1	1	4	1	4	4
128	1	1	3	2	4	4
129	1	1	2	3	4	4
130	1	1	1	4	4	4
131	1	1	6	5	4	4
132	1	1	5	6	4	4
133	2	1	4	1	4	3
134	2	1	3	2	4	3
135	2	1	2	3	4	3
136	2	1	1	4	4	3
137	2	1	6	5	4	3

Polarization code	Receptacle shell			Plug shell		
	Left key	Center key	Right key	Left post	Center post	Right post
138	2	1	5	6	4	3
139	3	1	4	1	4	2
140	3	1	3	2	4	2
141	3	1	2	3	4	2
142	3	1	1	4	4	2
143	3	1	6	5	4	2
144	3	1	5	5	4	2
145	4	6	4	1	5	1
146	4	6	3	2	5	1
147	4	6	2	3	5	1
148	4	6	1	4	5	1
149	4	6	6	5	5	1
150	4	6	5	6	5	1
151	5	6	4	1	5	6
152	5	6	3	2	5	6
153	5	6	2	3	5	6
154	5	6	1	4	5	6
155	5	6	6	5	5	6
156	5	6	5	6	5	6
157	6	6	4	1	5	5
158	6	6	3	2	5	5
159	6	6	2	3	5	5
160	6	6	1	4	5	5
161	6	6	6	5	5	5
162	6	6	5	6	5	5
163	1	6	4	1	5	4
164	1	6	3	2	5	4
165	1	6	2	3	5	4
166	1	6	1	4	5	4
167	1	6	6	5	5	4
168	1	6	5	6	5	4
169	2	6	4	1	5	3
170	2	6	3	2	5	3
171	2	6	2	3	5	3
172	2	6	1	4	5	3
173	2	6	6	5	5	3
174	2	6	5	6	5	3
175	3	6	4	1	5	2
176	3	6	3	2	5	2
177	3	6	2	3	5	2
178	3	6	1	4	5	2
179	3	6	6	5	5	2
180	3	6	5	6	5	2
181	4	5	4	1	6	1
182	4	5	3	2	6	1
183	4	5	2	3	6	1
184	4	5	1	4	6	1
185	4	5	6	5	6	1
186	4	5	5	6	6	1
187	5	5	4	1	6	6
188	5	5	3	2	6	6
189	5	5	2	3	6	6
190	5	5	1	4	6	6
191	5	5	6	5	6	6
192	5	5	5	6	6	6
193	6	5	4	1	6	5
194	6	5	3	2	6	5
195	6	5	2	3	6	5
196	6	5	1	4	6	5
197	6	5	6	5	6	5
198	6	5	5	6	6	5
199	1	5	4	1	6	4
200	1	5	3	2	6	4
201	1	5	2	3	6	4
202	1	5	1	4	6	4
203	1	5	6	5	6	4
204	1	5	5	6	6	4
205	2	5	4	1	6	3
206	2	5	3	2	6	3
207	2	5	2	3	6	3
208	2	5	1	4	6	3
209	2	5	6	5	6	3
210	2	5	5	6	6	3
211	3	5	4	1	6	2
212	3	5	3	2	6	2
213	3	5	2	3	6	2
214	3	5	1	4	6	2
215	3	5	6	5	6	2
216	3	5	5	6	6	2

SIGNAL AND POWER CRIMP CONTACTS SIZES 22, 20HD, 16, 12 & 5

Contact size	AWG	Cross section (mm ²)	Wire outside dia mm (inch)	Striping length mm (inch)	PIN	SOCKET	Crimping tool	Positionner	SEL	Ins/Ext tool
22	22 24 26	0.38 0.21 0.14	1.4 (0.055)	3.5 (0.138)	616200 (M39029/ 11-144)	616300 (M39029/ 12-148)	282281 (M22520/ 2-01)	282970 (M22520/ 2-23)	4 3 3	282885 (M81969/ 1-01)
22 reduced crimp barrel	28 30	0.093 0.055	1.2 (0.047)	3.5	616201	616301			5 4	
20HD	20 22 24	0.60 0.38 0.21	1.8 (0.071)	4.0 (0.157)	616210 (M39029/ 11-145)	616310 (M39029/ 12-149)	282281 (M22520/ 2-01)	282971 (M22520/ 2-08)	7 6 5	282886 (M81969/ 1-02)
20HD reduced crimp barrel	26 28 30	0.14 0.093 0.055	1.25 (0.049)	4.0 (0.157)	616211	616311			6 5 4	
16	16 18 20	1.34 0.93 0.60	2.6 (0.236)	6.0 (0.236)	616230 (M39029/ 11-146)	616330 (M39029/ 12-150)	282291 (M22520/1- 01)	282972 (M22520/ 1-02)	6 5 4	282546 (M81969/ 1-03)
16 reduced crimp barrel	20 22 24	0.60 0.38 0.21	1.80 (0.071)	6.0 (0.236)	616231	616331			5 4	
12	12 14 16	3.18 1.91 1.34	3.4 (0.134)	6.0 (0.236)	616240 (M39029/ 11-147)	616340 (M39029/ 11-151)	282296 (DANIELS M300BT) (See note 1)	282579 (M22520/ 1-11)	8 7 6	282547 (M81969/ 28-02)
For cavity 5	12 14	3.18 1.91	3.4 (0.134)	8.0 (0.315)	616261	616361			1 1	
	10 8	5.0 9.0	5.7 (0.234)		616266	616366	282557	5 8	282946 (M81969/ 28-01)	

THERMOCOUPLE CONTACTS SIZES 22 & 20HD MADE OF CHROMEL

Contact size	AWG	Cross section (mm ²)	Wire outside dia mm (inch)	Striping length mm (inch)	PIN	SOCKET	Crimping tool	Positionner	SEL	Ins/Ext tool
22	22 24 26	0.38 0.21 0.14	1.4 (0.055)	3.5 (0.138)	620280	620380	282281 (M22520/ 2-01)	282970 (M22520/ 2-23)	4 3 3	282885 (M81969/ 1-01)
20HD	20 22 24	0.60 0.38 0.21	1.8 (0.071)	4.0 (0.157)	620290	620390			282971 (M22520/ 2-08)	

THERMOCOUPLE CONTACTS SIZES 22 & 20HD MADE OF ALUMEL

Contact size	AWG	Cross section (mm ²)	Wire outside dia mm (inch)	Striping length mm (inch)	PIN	SOCKET	Crimping tool	Positionner	SEL	Ins/Ext tool
22	22 24 26	0.38 0.21 0.14	1.4 (0.055)	3.5 (0.138)	620281	620381	282281 (M22520/ 2-01)	282970 (M22520/ 2-23)	4 3 3	282885 (M81969/ 1-01)
20HD	20 22 24	0.60 0.38 0.21	1.8 (0.071)	4.0 (0.157)	620291	620391			282971 (M22520/ 2-08)	

NOTE:

(1) Daniels WA27-309-EP air pressure tool with crimp setting 5 can also be used. Crimp setting 5 is not adjustable and must be set by the factory.

CONTACTS

SIZES 22 & 20HD PC TAIL CONTACTS

Contact size	Contact arrangement	Pin	Socket	Ext. Tool	Dimensions mm (inch)				
					A	B	C	D	E
22	106	/	616379	282890	6.1/5.3 (0.240/0.209)	6.5 (0.256)	0.6 (0.023)	25.25/25.75 (0.994/1.013)	1.55/1.75 (0.061/0.069)
			616303		14.4/13.6 (0.567/0.535)	9.4 (0.370)			
	36C7 for pin contacts	616206*	616306*		5.9/6.7 (0.232/0.263)	3.8 (0.149)	/	/	7.85/7.44 (0.293/0.309)
			/		0.82/0.10 (0.032/0.004)				
	36C7 for socket contacts	/	616306		4/3.3 (0.157/0.130)	9.4 (0.370)	28.50/28.15 (1.122/1.108)	/	
			616303		11.72/11 (0.461/0.433)				
20HD	40-45-57-32C2-32C4-40C1	616216*	/	282891	6.6/7.6 (0.259/0.299)	/	0.8 (0.031)	31.25/31.75 (1.23/1.25)	7.45/7.75 (0.293/0.305)
	67-33C4				6.3/7.3 (0.248/0.287)				
	40-45-57-32C2-32C4-40C1	616223	616323*		3.5/4.3 (0.138/0.169)	3.2 (0.126)	0.6 (0.023)		
	67-33C4				3.2/4 (0.126/0.157)				

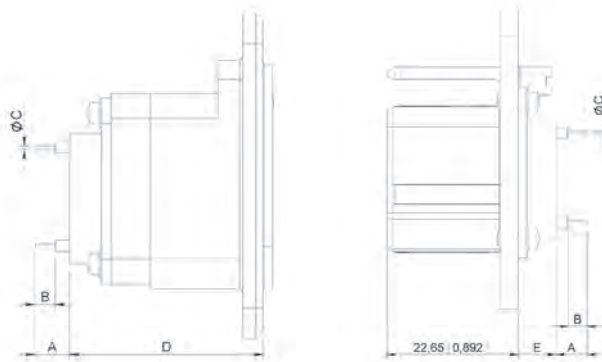

NOTE: * Connectors delivered in the "Y" termination style will be fitted with contacts marked by "*" (see above table). If you want to use another kind of pc tail contact, use termination style "x" when ordering the connector and order contacts separately.

SIZES 22 & 20HD WIRE WRAP CONTACTS

Contact size	AWG	Contact arrangement	Pin	Socket	Ins. tool	Dimensions			
						A	B	C	
22	26 28 30	106	610203 (2 wrap levels)	610303 (2 wrap levels)	282527	10/11 (0.393/0.433)	25.25/25.75 (0.994/1.013)	1.55/1.75 (0.061/0.069)	
			610204 (3 wrap levels)	610304 (3 wrap levels)		12.5/13.5 (0.492/0.531)			
	26 28 30	67-33C4	40-45-57-32C2-32C4-40C1	610214 (2 wrap levels)		610314 (2 wrap levels)	10.3/11.3 (0.405/0.445)	31.25/31.75 (1.203/1.250)	7.45/7.75 (0.293/0.305)
							9.85/10.95 (0.387/0.431)		

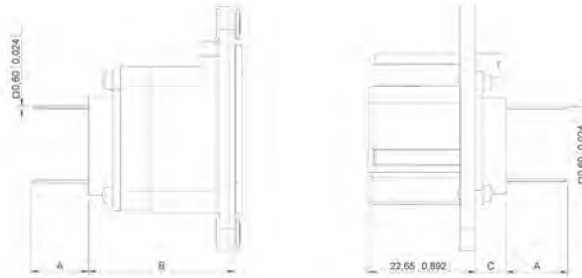

COAXIAL CRIMP CONTACTS SIZE 1 (design as per MS3168-3169 specifications)

Contact size	Contact arrangement	Cable (See note 1)	Pin	Socket	Center contact			Outer body		
					Crimping tool	Positioner	SEL	Crimping tool	Die	Hex
1	MC2	UT 141 RG 402	616005	/	Solder contact					
		RG 58 RG 141 KX 15	616006 right angle	/	Solder contact			282246 (M22520/5-05)	A	
		RG 213 KX 4	/	616102001	282291 (M22520/1-01)	282997 (M22520/1-13)	8			282247 (M22520/5-61)
		RG 214 RG 225	/	616103001						
			616003	/						
		RG 142	616007 right angle	/	Solder contact			282293 (M22520/5-01)	A	
		RG 142 RG 223	/	616107001	282291 (22520/1-01)	282997 (M22520/1-13)	7			282246 (M22520/5-05)
		RG 174 KX 22	/	616100	Solder contact					
		RD 316	616004 right angle	/	Solder contact				B	
/	616009	/	SMA Termination							

Part number	616004 - 616006 - 616007	616009 - 616100 - 616103001 616106 - 616102001	616003 - 616005 616107001
Dielectric withstanding voltage at sea level (V rms)	1000	1500	2500

NOTE:

(1) For other cable, please contact Radiall.

CONTACTS

COAXIAL CRIMP CONTACTS SIZE 3

Contact size	Contact arrangement	Cable (See note 1)	Pin	Socket	Center contact			Outer body		
					Crimping tool	Positioner	SEL	Crimping tool	Die	Hex
3	MC3	RG 142 RG 223	616013	/	Solder			282293 (M22520/5-01)	282246 (M22520/5-05)	A
		/	616113	282291 (M22520/1-01)	282997 (M22520/5-05)	7	B			
		RG 316	616015 Right angle (See note 1)	/	solder					
		UT 141 RG 402	616014	/	solder					
		RG 214 RG 225	/	616111	282291 (M22520/1-01)	282997 (M22520/5-05)	8	282293 (M22520/5-01)	282247 (M22520/5-61)	A
RG 213 KX 4	/	616112								

COAXIAL CRIMP CONTACTS SIZE 5 (design as per MS3172 specifications)

The following contacts have to be fitted with a sealing boot when used in DSX E connectors (see page 6-29). Coaxial cavities without any contact can be fitted with sealing plugs when used in DSX E connectors.

Contact size	Contact arrangement	Cable (See note 1)	Pin (See notes 3&4)	Socket (See notes 3&4)	Center contact			Outer body		
					Crimping tool	Positioner	SEL	Crimping tool	Die	Hex
5	32C2 32T2 33C4 33T4 36C7 36T7 40C1 40T1	RG 58 KX 15	616120	616020	282281 (M22520/2-01)	282974	6	282293 (M22520/5-01)	282246 (M22520/5-05)	A
		RG 141	616120	616020			8			
		RG 142 RG 223 KX 23	616121	616021			8			
		RG 179 RG 188 RG 174 RG316 KX 22	616122	616022			7			
		RG 179 RG 187	/	616022002		282550 DANIELS K345				B
		RG 196 RG 178 KX 21	616123	616023		282974	6			
		RG 195 RG 180	616124	616024			7			
		RG 316 DS	616163	616026						
		UT .085	616125	/	solder					
		UT .141	616128	616028	solder					



NOTES:

- (1) For other cable, please contact Radiall.
- (2) Dielectric withstanding voltage at sea level: 1500 V rms. Except 1000 V rms for 616015.
- (3) Dielectric withstanding voltage at sea level: 750 V rms.
- (4) Extraction tool: 282946 [M81969/28-01].

COAXIAL CRIMP CONTACTS SIZE 7

Contact size	Contact arrangement	Cable (See note 1)	Pin (See notes 263)	Socket (See notes 263)	Center contact			Outer body			
					Crimping tool	Positioner	SEL	Crimping tool	Die	Hex	
7	MC3	RG 58 RG 141 KX 15	610120	/	282281 (M22520/2-01)	282550 (DANIELS K345)	solder	282293 (M22520/5-01)	282246 (M22520/5-05)	A	
		RG 174 RG 316 KX 22 RG 188	610126	/						B	
		RG 58 KX 15	/	616030						6	A
		RG 141	/	616030						8	A
		RG 142 RG 223 KX 23	/	616031						8	A
		RG 174 RG 316 KX 22	/	616032						7	B

COAXIAL CRIMP CONTACTS SIZE 9

Add 001 at the end of each part number pin or socket to order environmental size 9 coax contacts. Coaxial cavities without any contact can be fitted with sealing plugs when used in DSX E connectors.

Contact size	Contact arrangement	Cable (See note 1)	Pin (See notes 263)	Socket (See notes 263)	Center contact			Outer body		
					Crimping tool	Positioner	SEL	Crimping tool	Die	Hex
9	C8 T8 32C4 32T4	RG 58 KX 15	616140	616040	282281 (M22520/2-01)	282974	6	282293 (M22520/5-01)	282246 (M22520/5-05)	A
		RG 141					8			
		RG 142 RG 223 KX 23	616141	616041			8			
		RG 174 RG 179 RG 188 RG 316 KX 22	616142	616042			7			B
		RG 178 RG196 KX 21	616143	616043			6			
		RG 180 RG 195	616144	616044			6			



COAXIAL CRIMP CONTACTS SIZE 15

Contact size	Contact arrangement	Cable (See note 1)	Pin (See notes 263)	Socket (See notes 263)	Center contact			Outer body		
					Crimping tool	Positioner	SEL	Crimping tool	Die	Hex
15	D8 26 67 32C4 32T4 33C4 33T4	RG 316 RG 179	616154	618050	282281 (M22520/2-01)	282974	2	282293 (M22520/5-01)	282246 (M22520/5-05)	/
		KX 22 DS	616150							
		KX 21 DS	616151	618053						
		RG 178 KX 21	616153	618054						

NOTES:

- (1) For other cable, please contact Radiall. - (2)
Dielectric withstanding voltage at sea level: 750 V rms.
(3) Extraction tool: 282946 (M81969/28-01). - (4)
Dielectric withstanding voltage at sea level: 350 V rms.

www.radiall.com

CONTACTS

CONCENTRIC TWINAX CRIMP CONTACTS SIZE 5 (design as per 17B9E4005 specifications)

Contact size	Contact arrangement	Cable	Pin	Socket
The following contacts have to be installed in the non environmental inserts.				
5	32C3 32T2 40C1 40T1 36C7 36T7 33C4 33T4	MIL-C-17/176-00002	616195001	616095001
		PAN 6421	616195005	616095005
The following contacts have to be installed in the environmental inserts				
5	32C3 32T2 40C1 40T1 33C4 33T4	MIL-C-17/176-00002	616195009	616095009
			36C7 36T7	616195012



CONCENTRIC TWINAX CRIMP CONTACTS SIZE 9 (design as per 17B9E4005 specifications)

Contact size	Contact arrangement	Cable	Pin	Socket
The following contacts have to be installed in the non environmental inserts.				
9	C8 T8 32C4 32T4	MIL-C-17/176-00002	616196003	616096003
The following contacts have to be installed in the environmental inserts				
9	C8 T8	MIL-C-17/176-00002	/	616096006
	32C4 32T4		616196004	616096004

TRIAx CRIMP CONTACTS SIZE 5

Contact size	Contact arrangement	Cable	Pin	Socket
The following contacts have to be installed in the non environmental inserts.				
5	33C4 33T4 32C2 32T2 40C1 40T1 36C7 36T7	RGX 179	616195004	616095004
		ST5M 1323-1	616195007	616095007
		HS4863-1 HS4863-2	616195000	616095000
The following contacts have to be installed in the environmental inserts				
5	36C7 36T7	RGX 179	/	616095010

TRIAx CRIMP CONTACTS SIZE 9

Contact size	Contact arrangement	Cable	Pin	Socket
The following contacts have to be installed in the non environmental inserts.				
9	C8 T8 32C4 32T4	RGX 179	616196001	616096001
The following contacts have to be installed in the environmental inserts				
9	32C4 32T4	RGX 179	/	616096002

TRIAx CONTACTS WITH PC TAIL SIZE 5

The contacts shown in the table below are rear release rear removable contacts.

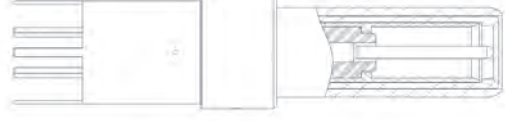
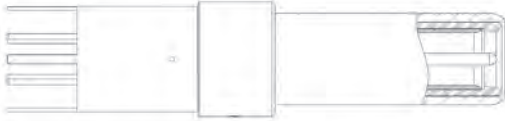
Contact type	Part number	Contact drawing	Rear extension from the insert mm (inch)
Pin	616195003		32C2, 32T2, 33C4, 33T4 40C1, & 40T1 = 3.2/4.0 (0.125/0.158)
	616195008		36C7 & 36T7 = 5.40/6.10 (0.212/0.240)

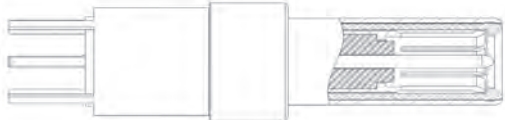
Contact type	Part number	Contact drawing	Rear extension from the insert mm (inch)
Pin	616196005		C8 & T8 = 1.30/2.15 (0.051/0.085) 32C4 & 32T4 = 6.45/7.30 (0.253/0.288)
	616196007		C8 & T8 = 0 32C4 & 32T4 = 3.70/4.35 (0.145/0.172)

FIBER OPTIC CONTACTS AND ACCESSORIES

MIL-PRF-29504 fiber optic termini were developed several decades ago and are described into several MIL standard documents. They fit into standard electrical cavities and do not require specific inserts. They can replace MIL-PRF-29504/10 pin and MIL-PRF-29504/11 socket termini.

MIL-PRF-29504 CONTACTS

Pin contact part number	Socket contact part number	Contact size	Fiber diameter (µm)	Cable diameter (mm)	Ferrule material
F724 005 000	F724 104 000	16	125	1.5	Ceramic
F724 011 000	F724 111 000	16	125	1.8	Ceramic
F724 009 000	F724 109 000	16	125	2	Ceramic
F724 002 000	F724 101 000	16	140	1.5	Ceramic
F724 041 000	F724 140 000	16	230	2	Metallic
F724 007 000	F724 107 000	16	280	1.6	Ceramic



Size 12 MIL-T-29504 contacts can be available upon request, please contact your Radiall sales representative. Note that Radiall can support you with your cable and harness assemblies. Please contact your sales representative.

ACCESSORIES

Radiall offers you a unique solution to equip your DSX connectors with EN4531 fiber optic contacts. This solution offers the following characteristics and advantages:



- It turns a ARINC 404 size 5 or size 8 cavity into a fiber optic link
- It accepts any EN4531-101 fiber optic contacts

EN4531-101 (ABS 1379) adapter for Quadrax size 8 cavity

	Part number	Description
	620946005	Pin quadrax adapter for EN4531 contact
	620946006	Socket quadrax adapter for EN4531 contact

EN4531-101 (ABS 1379) adapter for size 5 cavity

EN4531-101 adapter for size 5 cavity is available for DSX F connectors with inserts 33C4 and 81C3 only, see DSX F connectors page 6-41.

	Part number	Description
	616925001	Pin adapter for #5 cavity
	616925002	Socket adapter for #5 cavity

SEALING PLUGS AND FILLER PLUGS

Filler plugs are used in non environmental connectors and sealing plugs are used in environmental connectors and conform to MS27488.

Contact size	Sealing plugs	Filler plugs
Size 22	616910	620920
Size 20HD	616911	610941
Size 16	616912	620922
Size 12	616913	616923
Size 5	See notes	620924, 616923 (See note 1) or 616917 (See note 2) for pin contact cavity 620925 for socket contact cavity
Size 9	See notes	616915 (See note 2)

SEALING BOOTS

The sealing boots in table 1 are to be used in all inserts with size 5 contact cavities except 36C7 and 36T7 inserts which use the sealing bushing plus one in the sealing sleeves in table 2.

Table 1





Cable	X dia. mm (inch)	Part number	Drawing
RG58, RG142	4.3 (0.169)	92505490	
RG 174	2 (0.079)	92505470	
RG 178	1.4 (0.055)	92505460	
RG180	3.1 (0.122)	92505480	
/	0	92505450	

Table 2

Cable	X dia. mm (inch)	Sealing bushing	Sealing sleeve	Part number
RG58, RG141, RG142, RG223, KX15, KX23	4.7 (0.185)	92505590	92505591	
RG174, RG179, RG187, RG188, RG316, KX22, UT.085	2.15 (0.085)		92505593	
RG178, RG196	1.5 (0.059)		92505594	
RG180, RG195, UT.141	3.05 (0.120)		92505592	
/	0	616914010 (See note 3)		

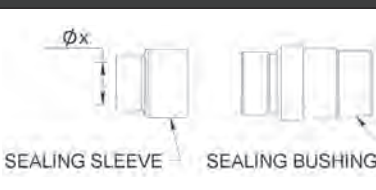
DUST CAPS

Conductive dust caps are made of thermoplastic and non conductive ones are made of polyethylene.

	Conductive (black)	Non Conductive (red)	Drawing
Plug	610804	610803	
Receptacle	610806	610805	

NOTES:

(1) 616923 is made of aluminium and is nickel plated.

(2) 616917 and 616915 provide interfacial sealing on class T connectors.

(3) 616914010 is made of PTFE.

ACCESSORIES

BACKSHELLS

The following backshells are only for use with SAE AS81659 and ARINC 404 shell type B connectors for the following modification codes 02 - 04 - 17 - 19 - 22 - 36 - 61 - 67 and 77.

Backshells cannot be installed on side 4 connectors due to limited screw access.

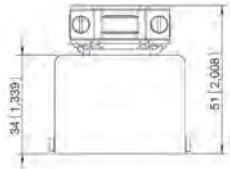
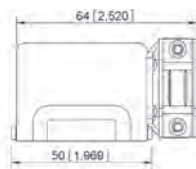
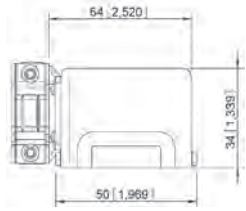
Entry type	Plating	Part number	Drawing
Top entry	Yellow anodized	610902	
	Nickel	610906	
Right entry	Yellow anodized	610900	
	Nickel	610910	
Left entry	Yellow anodized	610901	
	Nickel	610911	

DIMENSIONS

SHELL SIZE 1 NON ENVIRONMENTAL (without grommet seal)

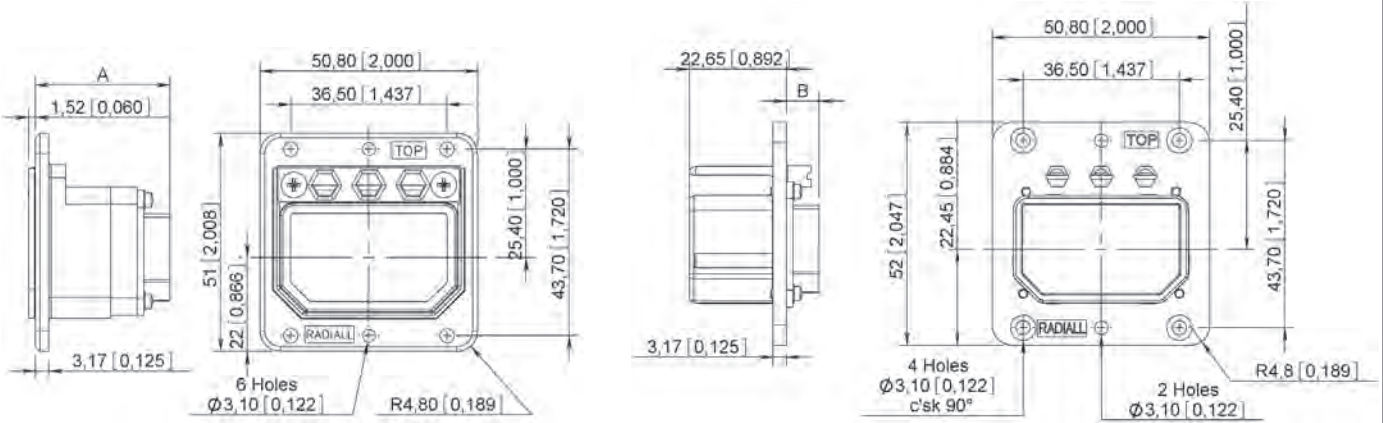

Max dimension mm (inch)	All crimp contact arrangements except 106	Contact arrangement 106	Arrangements with coax contacts size 1 & 3	Contact arrangement 36C7 & 36I7	Arrangements with coax contacts size 5 & 9 except 36C7
A	32 (1.260)	25.8 (1.016)	26.85 (1.057)	28.5 (1.122)	37.42 (1.473)
B	7.9 (0.311)	1.9 (0.075)	3 (0.118)	7.85 (0.309)	13.5 (0.531)

SHELL SIZE 1 ENVIRONMENTAL (with grommet seal)

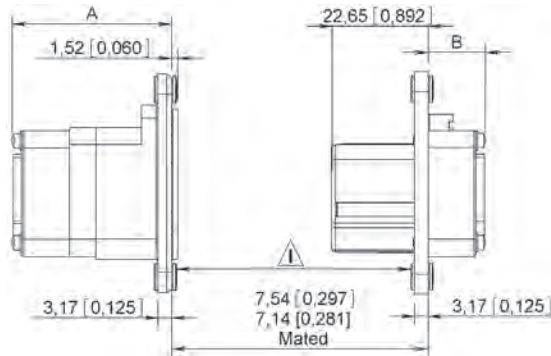

Max dimension mm (inch)	All crimp contact arrangements except MC2 - MC3 - 106	Contact arrangement 106
A	38.5 (1.516)	33.5 (1.319)
B	14.2 (0.559)	9.5 (0.374)

⚠ Important space available is only 4mm careful on the modification code selection.

DIMENSIONS

SHELL SIZE 2 NON ENVIRONMENTAL (without grommet seal)

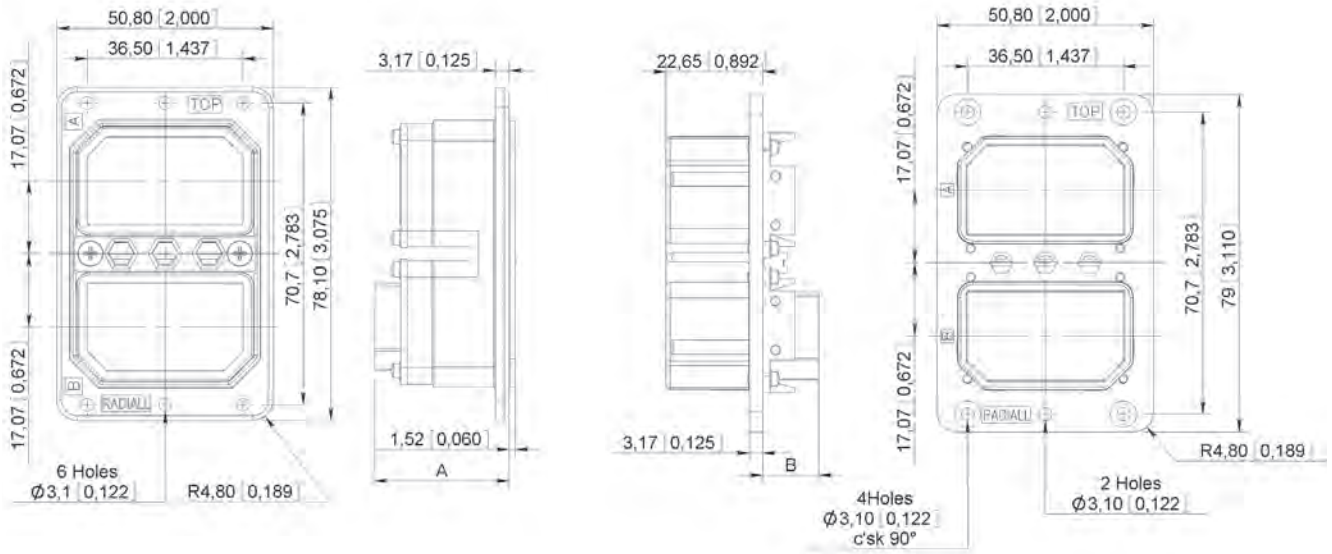

Max dimension mm (inch)	All crimp contact arrangements except 106	Contact arrangement 106	Arrangements with coax contacts size 1 & 3	Contact arrangement 36C7 & 36T7	Arrangements with coax contacts size 5 & 9 except 36C7
A	32 (1.260)	25.8 (1.016)	26.85 (1.057)	28.5 (1.122)	37.42 (1.473)
B	7.9 (0.311)	1.9 (0.075)	3 (0.118)	7.85 (0.309)	13.5 (0.531)

SHELL SIZE 2 ENVIRONMENTAL (with grommet seal)

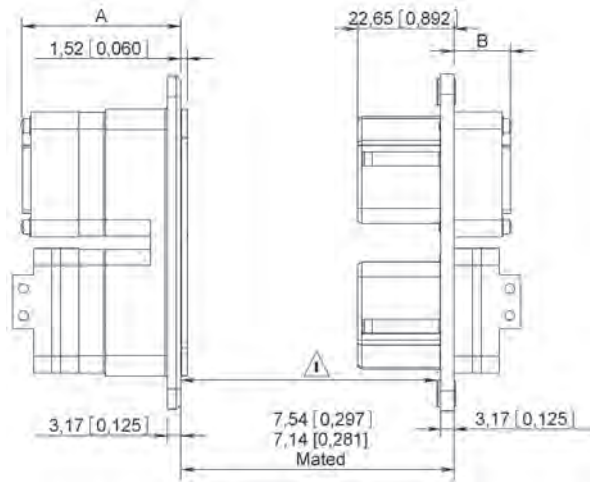

Max dimension mm (inch)	All crimp contact arrangements except MC2 - MC3 - 106	Contact arrangement 106
A	38.5 (1.516)	33.5 (1.319)
B	14.2 (0.559)	9.5 (0.374)

⚠ Important space available is only 4mm careful on the modification code selection.

SHELL SIZE 3 NON ENVIRONMENTAL (without grommet seal)

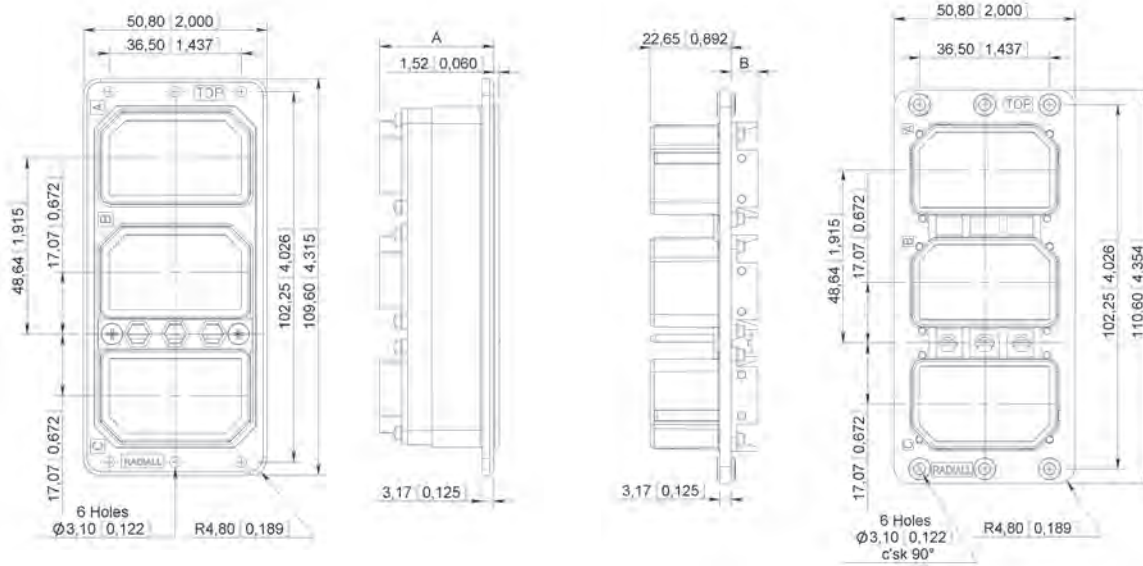

Max dimension mm (inch)	All crimp contact arrangements except 106	Contact arrangement 106	Arrangements with coax contacts size 1 & 3	Contact arrangement 36C7 & 36T7	Arrangements with coax contacts size 5 & 9 except 36C7
A	32 (1.260)	25.8 (1.016)	26.85 (1.057)	28.5 (1.122)	37.42 (1.473)
B	7.9 (0.311)	1.9 (0.075)	3 (0.118)	7.85 (0.309)	13.5 (0.531)

SHELL SIZE 3 ENVIRONMENTAL (with grommet seal)

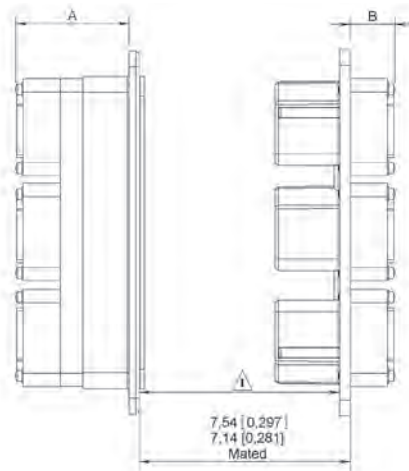

Max dimension mm (inch)	All crimp contact arrangements except MC2 - MC3 - 106	Contact arrangement 106
A	38.5 (1.516)	33.5 (1.319)
B	14.2 (0.559)	9.5 (0.374)

⚠ Important space available is only 4mm careful on the modification code selection.

DIMENSIONS

SHELL SIZE 4 NON ENVIRONMENTAL (without grommet seal)

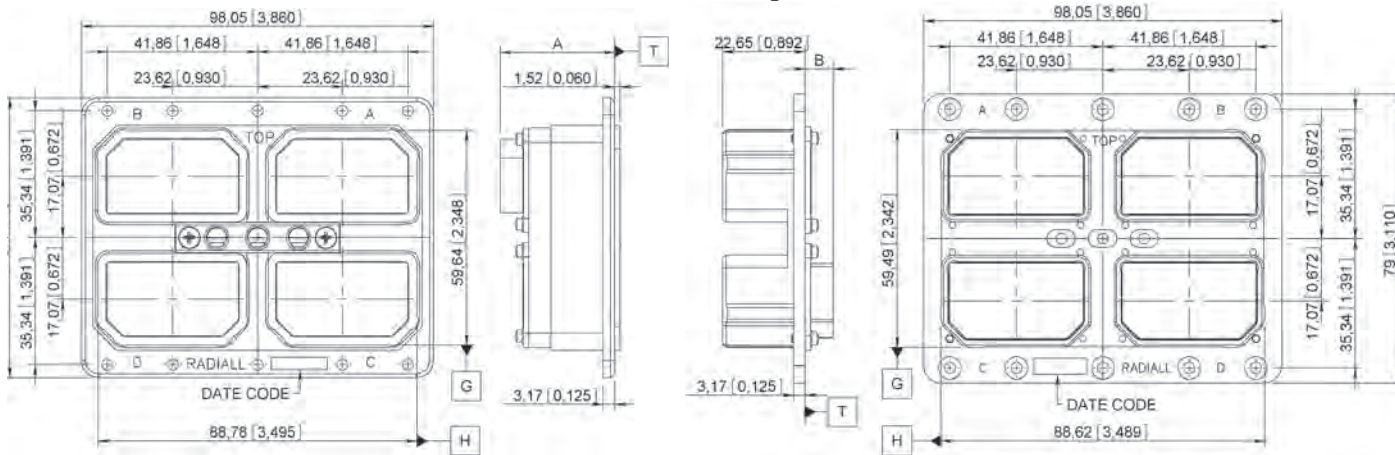

Max dimension mm (inch)	All crimp contact arrangements except 106	Contact arrangement 106	Arrangements with coax contacts size 1 & 3	Contact arrangement 36C7 & 36T7	Arrangements with coax contacts size 5 & 9 except 36C7
A	32 (1.260)	25.8 (1.016)	26.85 (1.057)	28.5 (1.122)	37.42 (1.473)
B	7.9 (0.311)	1.9 (0.075)	3 (0.118)	7.85 (0.309)	13.5 (0.531)

SHELL SIZE 4 ENVIRONMENTAL (with grommet seal)

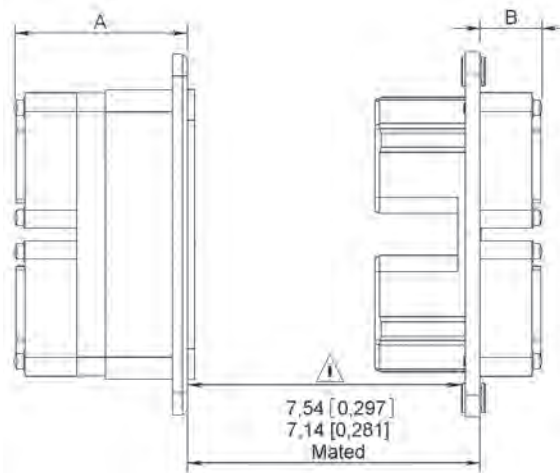

Max dimension mm (inch)	All crimp contact arrangements except MC2 - MC3 - 106	Contact arrangement 106
A	38.5 (1.516)	33.5 (1.319)
B	14.2 (0.559)	9.5 (0.374)

⚠ Important space available is only 4mm careful on the modification code selection.

SHELL SIZE 1

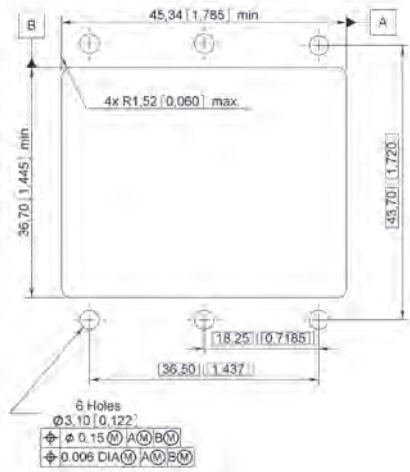

SHELL SIZE 2

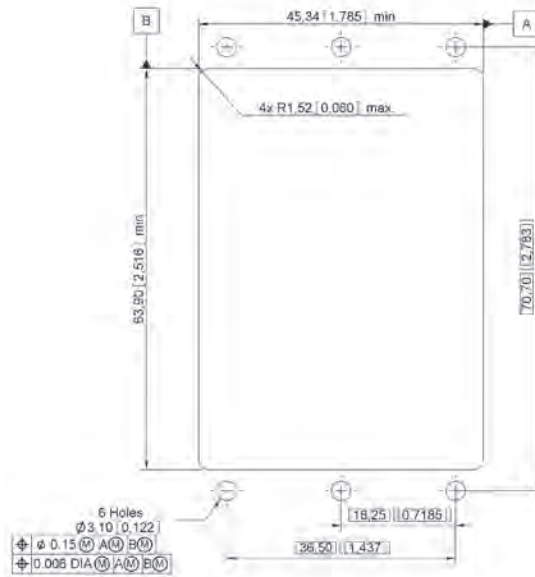

SHELL SIZE 3



SHELL SIZE 4

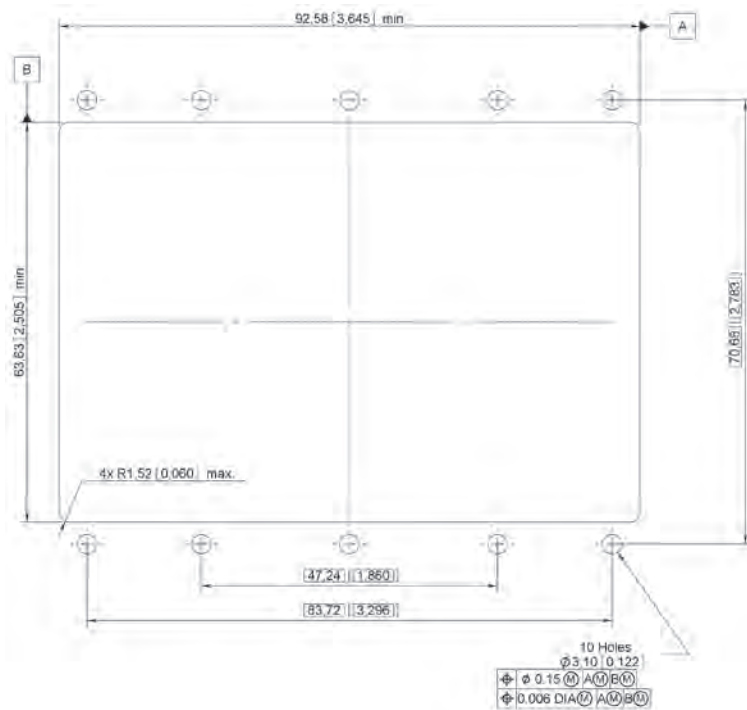

CROSS REFERENCE

From Radiall to Military P/N

Radiall part number	Mil part number
616200	M3902911144
616210	M3902911145
616230	M3902911146
616240	M3902911147
616300	M3902912148
616310	M3902912149
616330	M3902912150
616340	M3902912151
616910	MS2748822
616911	MS2748820
616912	MS2748816
616913	MS2748812
DSXE1PS106P73	M8165929A20041
DSXE1PS26S73	M8165929A20002
DSXE1PS32C2S73	M8165929A20140
DSXE1PS32C4S73	M8165929A20150
DSXE1PS33C4S73	M8165929A20104
DSXE1PS40C1S73	M8165929A20142
DSXE1PS40S73	M8165929A20010
DSXE1PS45S73	M8165929A20018
DSXE1PS57P73	M8165929A20025
DSXE1PS57S73	M8165929A20026
DSXE1PS67S73	M8165929A20034
DSXE1PSD8S73	M8165929A20084
DSXE1PXC8S73	M8165929A20136
DSXE1R32C4P00	M8165931A20149
DSXE1R33C4P00	M8165931A20103
DSXE1RS106S00	M8165931A20042
DSXE1RS26P00	M8165931A20001
DSXE1RS32C2P00	M8165931A20139
DSXE1RS40C1P00	M8165931A20141
DSXE1RS40P00	M8165931A20009
DSXE1RS45P00	M8165931A20017
DSXE1RS57P00	M8165931A20025
DSXE1RS57S00	M8165931A20026
DSXE1RS67P00	M8165931A20035
DSXE1RSD8P00	M8165931A20083
DSXE2PS106PS106P73	M8165933A20043
DSXE2PS106PS26S73	M8165933A20058
DSXE2PS106PS67S73	M8165933A20090
DSXE2PS106PXC8S73	M8165933A20088
DSXE2PS26SS106P73	M8165933A20060
DSXE2PS26SS26S73	M8165933A20004
DSXE2PS32C2SS106P73	M8165933A20130
DSXE2PS32C2SS40C1S73	M8165933A20122
DSXE2PS32C2SS45S73	M8165933A20124
DSXE2PS32C2SS57S73	M8165933A20126
DSXE2PS32C2SS67S73	M8165933A20128
DSXE2PS32C4SS106P73	M8165933A20152

Radiall part number	Mil part number
DSXE2PS32C4SXC8S73	M8165933A20160
DSXE2PS33C4SS106P73	M8165933A20106
DSXE2PS33C4SXC8S73	M8165933A20108
DSXE2PS40C1SS40C1S73	M8165933A20132
DSXE2PS40SS40S73	M8165933A20012
DSXE2PS45SS45S73	M8165933A20020
DSXE2PS57SS106P73	M8165933A20134
DSXE2PS57SS26S73	M8165933A20148
DSXE2PS57SS57S73	M8165933A20028
DSXE2PS67SS106P73	M8165933A20072
DSXE2PS67SS67S73	M8165933A20036
DSXE2PXC8SS106P73	M8165933A20118
DSXE2PXC8SS32C4S73	M8165933A20156
DSXE2PXC8SS57S73	M8165933A20146
DSXE2PXM2C2SS40C1S73	M8165933A20110
DSXE2PXM2C2SS57S73	M8165933A20112
DSXE2PXM2C3SS106P73	M8165933A20116
DSXE2PXM2C3SS67S73	M8165933A20114
DSXE2RS106SS106S00	M8165935A20044
DSXE2RS106SS26P00	M8165935A20057
DSXE2RS106SS67P00	M8165935A20089
DSXE2RS106SX8P00	M8165935A20087
DSXE2RS26PS106S00	M8165935A20059
DSXE2RS26PS26P00	M8165935A20003
DSXE2RS32C2PS106S00	M8165935A20129
DSXE2RS32C2PS40C1P00	M8165935A20121
DSXE2RS32C2PS45P00	M8165935A20123
DSXE2RS32C2PS57P00	M8165935A20125
DSXE2RS32C2PS67P00	M8165935A20127
DSXE2RS32C4PS106S00	M8165935A20151
DSXE2RS32C4PXC8P00	M8165935A20159
DSXE2RS33C4PS106S00**	M8165935A20105
DSXE2RS33C4PXC8P00**	M8165935A20107
DSXE2RS40C1PS40C1P00	M8165935A20131
DSXE2RS40PS40P00	M8165935A20011
DSXE2RS45PS45P00	M8165935A20019
DSXE2RS57PS106S00	M8165935A20133
DSXE2RS57PS26P00	M8165935A20147
DSXE2RS57PS57P00	M8165935A20027
DSXE2RS67PS106S00	M8165935A20071
DSXE2RS67PS67P00	M8165935A20035
DSXE2RXC8PS106S00	M8165935A20117
DSXE2RXC8PS32C4P00	M8165935A20155
DSXE2RXC8PS57P00	M8165935A20145
DSXE2RXMC2PS40C1P00	M8165935A20109
DSXE2RXMC2PS57P00	M8165935A20111
DSXE2RXMC3PS106S00	M8165935A20115
DSXE2RXMC3PS67P00	M8165935A20113
DSXE3PS106PS106PS106P73	M8165937A20045

Radiall part number	Mil part number
DSXE3PS106PS106PS32C4S73	M8165937A20158
DSXE3PS106PS106PS67S73	M8165937A20092
DSXE3PS26SS26SS26S73	M8165937A20006
DSXE3PS40SS40SS40S73	M8165937A20014
DSXE3PS45SS45SS45S73	M8165937A20022
DSXE3PS57SS57SS57S73	M8165937A20030
DSXE3PS67SS106PS67S73	M8165937A20080
DSXE3PS67SS67SS106P73	M8165937A20076
DSXE3PS67SS67SS67S73	M8165937A20038
DSXE3PS67SS67SXC8S73	M8165937A20074
DSXE3PXC8SXC8SS106P73	M8165937A20068
DSXE3PXC8SXC8SXC8S73	M8165937A20066
DSXE3RS106SS106SS106S00	M8165939A20046
DSXE3RS106SS106SS32C4P00	M8165939A20157
DSXE3RS106SS106SS67P00	M8165939A20091
DSXE3RS26PS26PS26P00	M8165939A20005
DSXE3RS40PS40PS40P00	M8165939A20013
DSXE3RS45PS45PS45P00	M8165939A20021
DSXE3RS57PS57PS57P00	M8165939A20029
DSXE3RS67PS106SS67P00	M8165939A20079
DSXE3RS67PS67PS106S00	M8165939A20075
DSXE3RS67PS67PS67P00	M8165939A20037
DSXE3RS67PS67PXC8P00	M8165939A20073
DSXE3RXC8PXC8PS106S00	M8165939A20067
DSXE3RXC8PXC8PXC8P00	M8165939A20065
DSXE4PS106PS106PS106PS106P73	M8165941A20047
DSXE4PS106PS106PS67SS67S73	M8165941A20102
DSXE4PS106PS67SS106PSC8S73	M8165941A20098
DSXE4PS106PS67SSC8SSC8S73	M8165941A20100
DSXE4PS26SS26SS26SS26S73	M8165941A20008
DSXE4PS40SS40SS40SS40S73	M8165941A20016
DSXE4PS45SS45SS45SS45S73	M8165941A20024
DSXE4PS57SS57SS57SS57S73	M8165941A20032
DSXE4PS67SS67SS33C4SS33C4S73	M8165941A20082
DSXE4PS67SS67SS67SS67S73	M8165941A20040
DSXE4PSC8SSC8SS67SS67S73	M8165941A20086
DSXE4RS106SS106SS106SS106S00	M8165943A20048
DSXE4RS106SS106SS67PS67P00	M8165943A20101
DSXE4RS106SS67PS106SSC8P00	M8165943A20097
DSXE4RS106SS67PSC8PSC8P00	M8165943A20099
DSXE4RS106SSC8PS106SS106S00	M8165943A20095
DSXE4RS26PS26PS26PS26P00	M8165943A20007
DSXE4RS26PS26PS26S00	M8165943A20061
DSXE4RS40PS40PS40PS40P00	M8165943A20015
DSXE4RS45PS45PS45PS45P00	M8165943A20023
DSXE4RS57PS57PS57PS57P00	M8165943A20031
DSXE4RS67PS67PS67PS67P00	M8165943A20039
DSXE4RSC8PSC8PSC8PSC8P00	M8165943A20085
DSXN1PS106P73**	M8165965A20041
DSXN1PS26S73	M8165965A20002
DSXN1PS32C2S73	M8165965A20140
DSXN1PS32C4P73	M8165965A20149
DSXN1PS32C4S73	M8165965A20150
DSXN1PS33C4S73	M8165965A20104
DSXN1PS40C1S73	M8165965A20142
DSXN1PS40S73	M8165965A20010

Radiall part number	Mil part number
DSXN1PS45P73	M8165965A20017
DSXN1PS45S73	M8165965A20018
DSXN1PS57P73	M8165965A20025
DSXN1PS57S73	M8165965A20026
DSXN1PS67S73	M8165965A20034
DSXN1PSD8S73	M8165965A20084
DSXN1PXC8S73	M8165965A20136
DSXN1RS106S00	M8165966A20042
DSXN1RS106S01	M8165967A20042
DSXN1RS106S23	M8165968A20042
DSXN1RS26P00	M8165966A20001
DSXN1RS26P01	M8165967A20001
DSXN1RS26P23	M8165968A20001
DSXN1RS32C2P00	M8165966A20139
DSXN1RS32C2P01	M8165967A20139
DSXN1RS32C2P23	M8165968A20139
DSXN1RS32C4P00	M8165966A20149
DSXN1RS32C4P01	M8165967A20149
DSXN1RS32C4P23	M8165968A20149
DSXN1RS33C4P00**	M8165966A20103
DSXN1RS33C4P01	M8165967A20103
DSXN1RS33C4P23	M8165968A20103
DSXN1RS40C1P00	M8165966A20141
DSXN1RS40C1P01	M8165967A20141
DSXN1RS40C1P23	M8165968A20141
DSXN1RS40P00	M8165966A20009
DSXN1RS40P01	M8165967A20009
DSXN1RS40P23	M8165968A20009
DSXN1RS45P00	M8165966A20017
DSXN1RS45P01	M8165967A20017
DSXN1RS45P23	M8165968A20017
DSXN1RS57P00	M8165966A20025
DSXN1RS57P01	M8165967A20025
DSXN1RS57P23	M8165968A20025
DSXN1RS57S00	M8165966A20026
DSXN1RS67P00	M8165966A20033
DSXN1RS67P01	M8165967A20033
DSXN1RS67P23	M8165968A20033
DSXN1RSD8P00	M8165966A20083
DSXN1RSD8P01	M8165967A20083
DSXN1RSD8P23	M8165968A20083
DSXN1RXC8P00	M8165966A20135
DSXN1RXC8P01	M8165967A20135
DSXN1RXC8P23	M8165968A20135
DSXN2PS106PS106P73	M8165969A20043
DSXN2PS106PS26S73	M8165969A20058
DSXN2PS106PS67S73	M8165969A20090
DSXN2PS106PXC8S73	M8165969A20088
DSXN2PS26SS106P73	M8165969A20060
DSXN2PS26SS26S73	M8165969A20004
DSXN2PS32C2SS106P73	M8165969A20130
DSXN2PS32C2SS40C1S73	M8165969A20122
DSXN2PS32C2SS45S73	M8165969A20124
DSXN2PS32C2SS57S73	M8165969A20126
DSXN2PS32C2SS67S73	M8165969A20128
DSXN2PS32C4SS106P73	M8165969A20152

Radiall part number	Mil part number
DSXN2PS32C4SXC8S73	M8165969A20160
DSXN2PS33C4SS106P73**	M8165969A20106
DSXN2PS33C4SXC8S73**	M8165969A20108
DSXN2PS40C1SS40C1S73	M8165969A20132
DSXN2PS40SS40S73	M8165969A20012
DSXN2PS45SS45S73	M8165969A20020
DSXN2PS57SS106P73	M8165969A20134
DSXN2PS57SS26S73	M8165969A20148
DSXN2PS57SS57S73	M8165969A20028
DSXN2PS67SS106P73	M8165969A20072
DSXN2PS67SS67S73	M8165969A20036
DSXN2PXC8SS106P73	M8165969A20118
DSXN2PXC8SS32C4S73	M8165969A20156
DSXN2PXC8SS57S73	M8165969A20146
DSXN2PXM2SS40C1S73	M8165969A20110
DSXN2PXM2SS57S73	M8165969A20112
DSXN2PXM2SS106P73	M8165969A20116
DSXN2PXM2SS67S73	M8165969A20114
DSXN2RS106SS106S00	M8165970A20044
DSXN2RS106SS106S01	M8165971A20044
DSXN2RS106SS106S23	M8165972A20044
DSXN2RS106SS26P00	M8165970A20057
DSXN2RS106SS26P01	M8165971A20057
DSXN2RS106SS26P23	M8165972A20057
DSXN2RS106SS67P00	M8165970A20089
DSXN2RS106SS67P01	M8165971A20089
DSXN2RS106SS67P23	M8165972A20089
DSXN2RS106SXC8P00	M8165970A20087
DSXN2RS106SXC8P01	M8165971A20087
DSXN2RS106SXC8P23	M8165972A20087
DSXN2RS26PS106S00	M8165970A20059
DSXN2RS26PS106S01	M8165971A20059
DSXN2RS26PS106S23	M8165972A20059
DSXN2RS26PS26P00	M8165970A20003
DSXN2RS26PS26P01	M8165971A20003
DSXN2RS26PS26P23	M8165972A20003
DSXN2RS32C2PS106S00	M8165970A20129
DSXN2RS32C2PS106S01	M8165971A20129
DSXN2RS32C2PS106S23	M8165972A20129
DSXN2RS32C2PS40C1P00	M8165970A20121
DSXN2RS32C2PS40C1P01	M8165971A20121
DSXN2RS32C2PS40C1P23	M8165972A20121
DSXN2RS32C2PS45P00	M8165970A20123
DSXN2RS32C2PS45P01	M8165971A20123
DSXN2RS32C2PS45P23	M8165972A20123
DSXN2RS32C2PS57P00	M8165970A20125
DSXN2RS32C2PS57P01	M8165971A20125
DSXN2RS32C2PS57P23	M8165972A20125
DSXN2RS32C2PS67P00	M8165970A20127
DSXN2RS32C2PS67P01	M8165971A20127
DSXN2RS32C2PS67P23	M8165972A20127
DSXN2RS32C4PS106S00	M8165970A20151
DSXN2RS32C4PS106S01	M8165971A20151
DSXN2RS32C4PS106S23	M8165972A20151
DSXN2RS32C4PXC8P00	M8165970A20159
DSXN2RS32C4PXC8P01	M8165971A20159

Radiall part number	Mil part number
DSXN2RS32C4PXC8P23	M8165972A20159
DSXN2RS33C4PS106S00	M8165970A20105
DSXN2RS33C4PS106S01	M8165971A20105
DSXN2RS33C4PS106S23	M8165972A20105
DSXN2RS33C4PXC8P00	M8165970A20107
DSXN2RS33C4PXC8P01	M8165971A20107
DSXN2RS33C4PXC8P23	M8165972A20107
DSXN2RS40C1PS40C1P00	M8165970A20131
DSXN2RS40C1PS40C1P01	M8165971A20131
DSXN2RS40C1PS40C1P23	M8165972A20131
DSXN2RS40PS40P00	M8165970A20011
DSXN2RS40PS40P01	M8165971A20011
DSXN2RS40PS40P23	M8165972A20011
DSXN2RS45PS45P00	M8165970A20019
DSXN2RS45PS45P01	M8165971A20019
DSXN2RS45PS45P23	M8165972A20019
DSXN2RS57PS106S00	M8165970A20133
DSXN2RS57PS106S01	M8165971A20133
DSXN2RS57PS106S23	M8165972A20133
DSXN2RS57PS26P00	M8165970A20147
DSXN2RS57PS26P01	M8165971A20147
DSXN2RS57PS26P23	M8165972A20147
DSXN2RS57PS57P00	M8165970A20027
DSXN2RS57PS57P01	M8165971A20027
DSXN2RS57PS57P23	M8165972A20027
DSXN2RS67PS106S00	M8165970A20071
DSXN2RS67PS106S01	M8165971A20071
DSXN2RS67PS106S23	M8165972A20071
DSXN2RS67PS67P00	M8165970A20035
DSXN2RS67PS67P01	M8165971A20035
DSXN2RS67PS67P23	M8165972A20035
DSXN2RXC8PS106S00	M8165970A20117
DSXN2RXC8PS106S01	M8165971A20117
DSXN2RXC8PS106S23	M8165972A20117
DSXN2RXC8PS32C4P00	M8165970A2-0155
DSXN2RXC8PS32C4P01	M8165971A20155
DSXN2RXC8PS32C4P23	M8165972A20155
DSXN2RXC8PS57P00	M8165970A20145
DSXN2RXC8PS57P01	M8165971A20145
DSXN2RXC8PS57P23	M8165972A20145
DSXN2RXMC2PS40C1P01	M8165971A20109
DSXN2RXMC2PS40C1P23	M8165972A20109
DSXN2RXMC2PS57P00	M8165970A20111
DSXN2RXMC2PS57P01	M8165971A20111
DSXN2RXMC2PS57P23	M8165972A20111
DSXN2RXMC2S40C1P00	M8165970A20109
DSXN2RXMC3PS106S00	M8165970A20115
DSXN2RXMC3PS106S01	M8165971A20115
DSXN2RXMC3PS106S23	M8165972A20115
DSXN2RXMC3PS67P00	M8165970A20113
DSXN2RXMC3PS67P01	M8165971A20113
DSXN2RXMC3PS67P23	M8165972A20113
DSXTIRS106S00	M8165961A20042
DSXTIRS26P00	M8165961A20001
DSXTIRS32C2P00	M8165961A20139
DSXTIRS32C4P00	M8165961A20149

Radiall part number	Mil part number
DSXT1RS33C4P00	M8165961A20103
DSXT1RS40C1P00	M8165961A20141
DSXT1RS40P00	M8165961A20009
DSXT1RS45P00	M8165961A20017
DSXT1RS57P00	M8165961A20025
DSXT1RS67P00	M8165961A20033
DSXT1RSD8P00	M8165961A20083
DSXT1RXC8P00	M8165961A20135
DSXT2RS106SS106S00	M8165962A20044
DSXT2RS106SS26P00	M8165962A20057
DSXT2RS106SS67P00	M8165962A20089
DSXT2RS106SXC8P00	M8165962A20087
DSXT2RS26PS106S00	M8165962A20059
DSXT2RS26PS26P00	M8165962A20003
DSXT2RS32C2PS106S00	M8165962A20129
DSXT2RS32C2PS40C1P00	M8165962A20121
DSXT2RS32C2PS45P00	M8165962A20123
DSXT2RS32C2PS57P00	M8165962A20125
DSXT2RS32C2PS67P00	M8165962A20127
DSXT2RS32C4PS106S00	M8165962A20151
DSXT2RS32C4PXC8P00	M8165962A20159
DSXT2RS33C4PS106S	M8165962A20105
DSXT2RS33C4PXC8P00	M8165962A20107
DSXT2RS40C1PS40C1P00	M8165962A20131
DSXT2RS40PS40P00	M8165962A20011
DSXT2RS45PS45P00	M8165962A20019
DSXT2RS57PS106S00	M8165962A20133
DSXT2RS57PS26P00	M8165962A20147
DSXT2RS57PS57P00	M8165962A20027
DSXT2RS67PS106S00	M8165962A20071
DSXT2RS67PS67P00	M8165962A20035

Radiall part number	Mil part number
DSXT2RXC8PS106S00	M8165962A20117
DSXT2RXC8PS32C4P00	M8165962A20155
DSXT2RXC8PS57P00	M8165962A20145
DSXT2RXMC2PS40C1P00	M8165962A20109
DSXT2RXMC2PS57P00	M8165962A20111
DSXT2RXMC3PS106S00	M8165962A20115
DSXT2RXMC3PS67P00	M8165962A20113
DSXT3RS106SS106SS106S00	M8165963A20046
DSXT3RS106SS106SS32C4P00	M8165963A20157
DSXT3RS106SS106SS67P00	M8165963A20091
DSXT3RS26PS26PS26P00	M8165963A20005
DSXT3RS40PS40PS40P00	M8165963A20013
DSXT3RS45PS45PS45P00	M8165963A20021
DSXT3RS57PS57PS57P00	M8165963A20029
DSXT3RS67PS106SS67P00	M8165963A20079
DSXT3RS67PS67PS106S00	M8165963A20075
DSXT3RS67PS67PS67P00	M8165963A20037
DSXT3RS67PS67PXC8P00	M8165963A20073
DSXT3RXC8PXC8PS106S00	M8165963A20067
DSXT3RXC8PXC8PXC8P00	M8165963A20065
DSXT4RS106SS106SS106SS106S00	M8165964A20048
DSXT4RS106SS106SS67PS67P00	M8165964A20101
DSXT4RS106SS67PS106SSC8P00	M8165964A20097
DSXT4RS106SS67PSC8PSC8P00	M8165964A20099
DSXT4RS106SSC8PS106SS106S00	M8165964A20095
DSXT4RS26PS26PS26PS26P00	M8165964A20007
DSXT4RS40PS40PS40PS40P00	M8165964A20015
DSXT4RS45PS45PS45PS45P00	M8165964A20023
DSXT4RS57PS57PS57PS57P00	M8165964A20031
DSXT4RS67PS67PS33C4PS33C4P00	M8165964A20081
DSXT4RSC8PSC8PS67PS67P00	M8165964A20085



HOW TO ORDER DSX-F CONNECTORS

DSX	F	4	R	Y	40	P	Y40P	Y26P	Y45P	00	01
-----	---	---	---	---	----	---	------	------	------	----	----

Series

Class

F: Front release front removable contacts, inserts without interfacial seal

K: Front release front removable contacts, inserts with interfacial seal

Shell size

- 1 : One gang shell
- 2 : Two gang shell
- 3 : Three gang shell
- 4 : Four gang shell

Shell type

- R : Receptacle
- P : Plug

Termination style

- X : Without contacts
- V : Wire wrap two levels
- W : Wire wrap three levels
- Y : PC tail contact

Contact arrangement ⁽¹⁺²⁾

To be chosen among the following: ⁽⁴⁾ 26 - 40 - 45 - 57 - 67 - 33C4 - 106 - 81C3

Contact type

- S : Socket
- P : Pin

Gang B

Gang C

Gang D

Gang A

Modification code

See pages from 6-13 to 6-19 for selection

Polarization code ^[See note 3]

See page 6-20 for selection

For Technical Characteristics please see page 6-7.

NOTES:

- (1) For mixed contact arrangements, order coax contacts separately see contacts available on pages 6-24 to 6-26. Coax contacts are rear release rear removable.
- (2) For 33C4 and 67 contact arrangements, size 16 contacts cavities are for front release front removable contacts. Size 16 contacts are to be ordered separately.
- (3) Without polarization code the connector is delivered with the polarizing system unassembled.
Polarization code 00: the connector is delivered without polarizing system.
Polarization code from 01 to 216: the connector is delivered with polarization hardware assembled as defined by code.
- (4) Contact arrangement 26 and 40 available only in class F connector version.

CONTACTS WITH PC TAIL SIZES 22, 20HD & 16

Contacts are delivered installed in the connector.

Contact size	Contact arrangement	Pin	Socket	Ins / Ext tool	Dimensions mm (inch)	
					A	B
22	81C3 -106	/	620361	282500	5.95/6.75 (0.234/0.265)	6 +/-0,03 (0.023)
20HD	40-45-67-33C4-57	616220	/	282503	4.3/5.1 (0.169/0.200)	
16 (See note 1)	26-67-33C4	616235	/	282504	3.55/4.32 (0.140/0.170)	Max. 1 (0.039)
		616235010	/			
		616234	/		10.20/11 (0.400/0.433)	

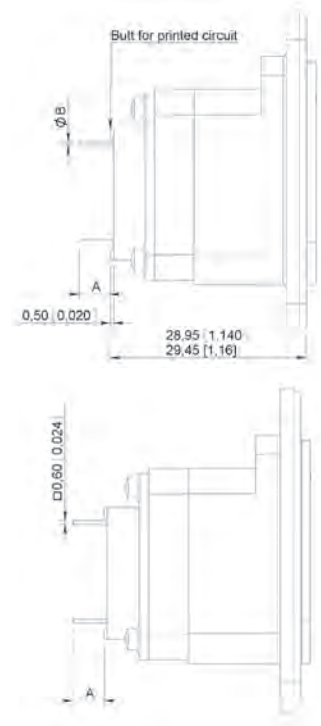

CONTACTS WITH WIRE WRAP POST SIZES 22 & 20HD

Contacts are delivered installed in the connector. For 67 and 33C4 contact arrangements, front release front removable size 12 and 16 contacts are not delivered with the connector. They must be ordered separately and chosen among size 16 PC tail contacts and 616326 size 16 solder cup contact (rear extension from insert: 4.4/5.2 (0.173/0.204)).

Contact size	AWG	Contact arrangement	Pin	Socket	Ins / Ext tool	Dimensions A mm (inch)
22	26 28 30	106	/	620351 (2 wraps levels)	282500	9.45/10.45 (0.372/0.412)
				620352 (3 wrap levels)		12.75/13.75 (0.502/0.541)
20HD	26 28 30	40-45-67-33C4-57	616222 (2 wraps levels)	/	282503	10/11 (0.394/0.433)
			616224 (3 wrap levels)			13.3/14.3 (0.523/0.563)

COAXIAL CRIMP CONTACTS FOR 33C4 CONTACT ARRANGEMENTS SIZE 5

These coaxial contacts are rear release rear removable and designed to be installed in 33C4 and 81C3 contact arrangement class F or K. They must be ordered separately.

Contact size	Contact arrangement	Cable	Pin	Socket	Center contact			Outer body		
					Crimping tool	Positioner	SEL	Crimping tool	Die	Hex
5	33C4 81C3	Microdot 250.39.37	616126	/	282281 (M22550/2-01)	282974	6	282293 (M22520/5-01)	282246 (M22520/5-05)	B
		RG 178 KX 21	616127	/						

EN4531-101 (ABS 1379) ADAPTER FOR SIZE 5 CAVITY

Radiall offers you a unique solution to equip your DSX connectors with EN4531 fiber optic contacts. The adapter will turn a ARINC 404 size 5 cavity into a fiber optic link, using EN4531-101 fiber optic contacts.

EN4531-101 adapter for size 5 cavity is available for DSX F connectors with inserts 33C4 and 81C3 only, see page 6-28.

NOTE:

(1) Front release front removable size 16 contacts PC tail termination are installed only for 26 contact arrangement (which is fitted with 616235 contacts). For 67 and 33C4, contact arrangements front release front removable size 16 contacts must be ordered separately.

HOW TO ORDER DSX-DATA BUS CONNECTORS

DSX	E	2	P	B4TP	S67S	00	01
-----	---	---	---	------	------	----	----

Series _____

Class _____

N: Non environmental (without grommet and interfacial seal)
E: Environmental (with grommet and interfacial seal)
T: Connector with interfacial seal on insert with protruding contacts only

Shell size _____

1 : One gang shell
2 : Two gang shell
3 : Three gang shell
4 : Four gang shell

Shell type _____

R : Receptacle
P : Plug

Gang A BUS contact arrangement ^(See note 1) _____
Refer to page 6-43

Gang B contact arrangement _____
Refer to page 6-43

Modification code _____
See from page 6-13 to 6-19

Polarization code _____
See page 6-20 for selection

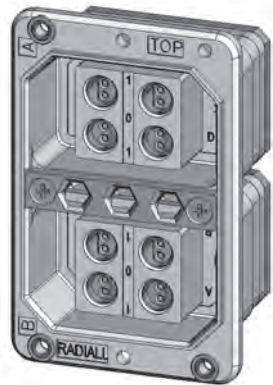







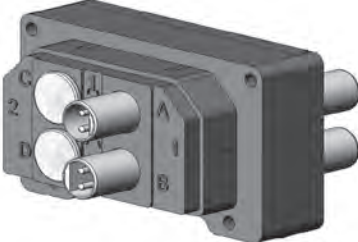

For Technical Characteristics please see pages 6-7.
For any additional information ask for the RP2667 DSX Data Bus from Radiall.

NOTES:
(1) Data bus contact arrangements have no interfacial seal and no rear grommet.

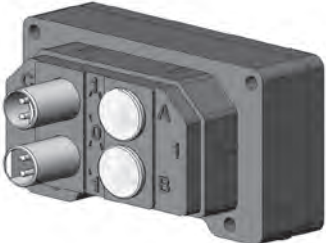
CONTACT ARRANGEMENTS

DSX series

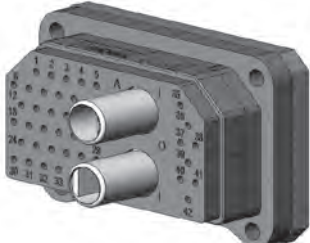
PIN INSERT MATING SIDE SHOWN – All inserts DWV 1000 V AC

Insert name	Number of contacts	Insert name	Number of contacts
B2TP1 – H2TP1	 2 x Twinax Location A, B	B2S1	 2 x Twinax Location A, B
B2TP2 – H2TP2	 2 x Twinax Location C, D	B2S2	 2 x Twinax Location C, D
B4TP – H4TP	 4 x Twinax Location A, B, C, D	B4S	 4 x Twinax Location A, B, C, D
S42B2P	 2 x Twinax 42 x #20HD Location A, B,	S42B2S	 2 x Twinax 42 x #20HD Location A, B,

DIMENSIONS

B2TP, H2TP, B4TP & H4TP AIRCRAFT CONNECTOR

The aircraft connector is comprised of two sub assemblies.

- 1- A plug shell fitted with an insert incorporating 2 (B2TP or H2TP) or 4 (B4TP or H4TP) twinax pin contacts.
- 2- One or two connection plugs depending on the number of BUS lines (B2 or B4). If there are two BUS lines (B2TP or H2TP) the two twinax contacts and the connection plug can be installed either in position 1 (B2TP1 or H2TP1) or in position 2 (B2TP2 or H2TP2).

The difference between B2TP1 and H2TP1, B2TP2 and H2TP2, B4TP and H4TP depends on the shielded twisted pairs cable that is used.

For Fileca F2709/12 cable the designation used are B2TP1, B2TP2, B4TP.

Description: differential impedance = $75 \pm 5\Omega$

Shielded twisted pair (each conductor = AWG 20) Outer diameter = 5.35mm (0.206 inch max)

For Fileca F2709/9 cable the designation used are H2TP1, H2TP2, H4TP.

Description: differential impedance = $75 \pm 5\Omega$

Shielded twisted pair (each conductor = AWG 22) Outer diameter = 4.80mm (0.189 inch max)

MATING FACE

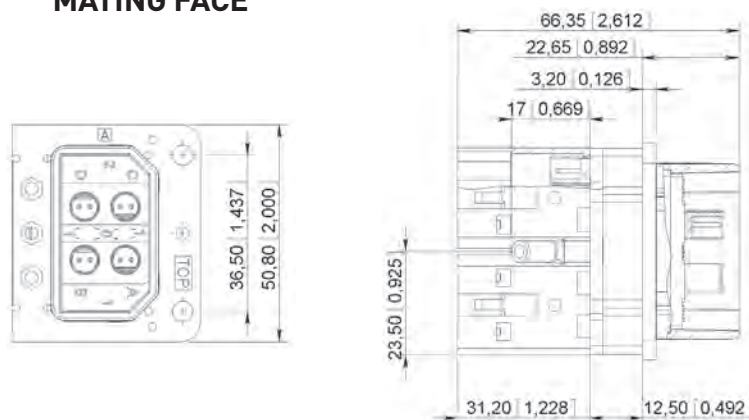

WIRING REAR FACE

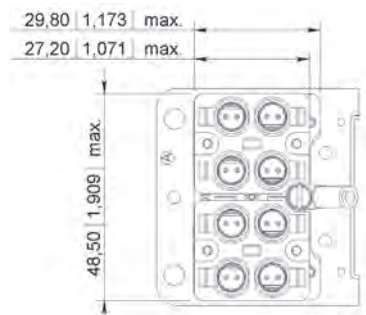

B2TP, H2TP, B4TP & H4TP EQUIPMENT CONNECTOR

The equipment connector is comprised of one receptacle shell fitted with an insert incorporating 2 (B2S) or 4 (B4S) twinax socket contacts.

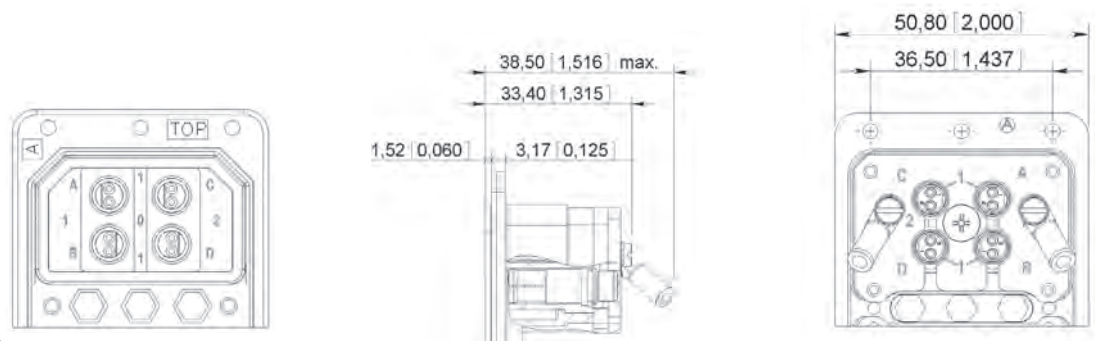

DIMENSIONS

S42B2P AIRCRAFT CONNECTOR

The aircraft connector is comprised of a plug shell fitted with a S42B2P insert.

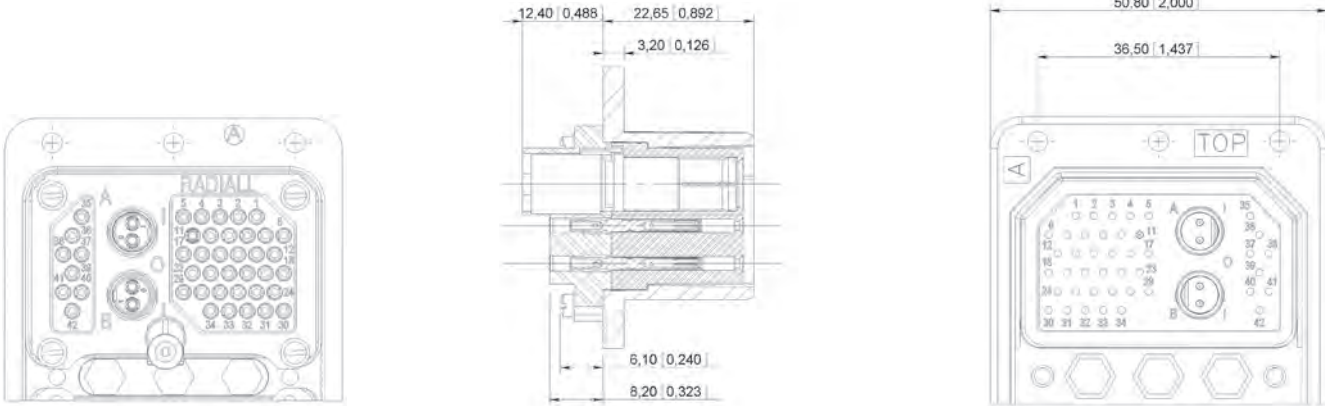

S42B2P EQUIPMENT CONNECTOR

The equipment connector is comprised of a receptacle shell fitted with a S42B2P insert.

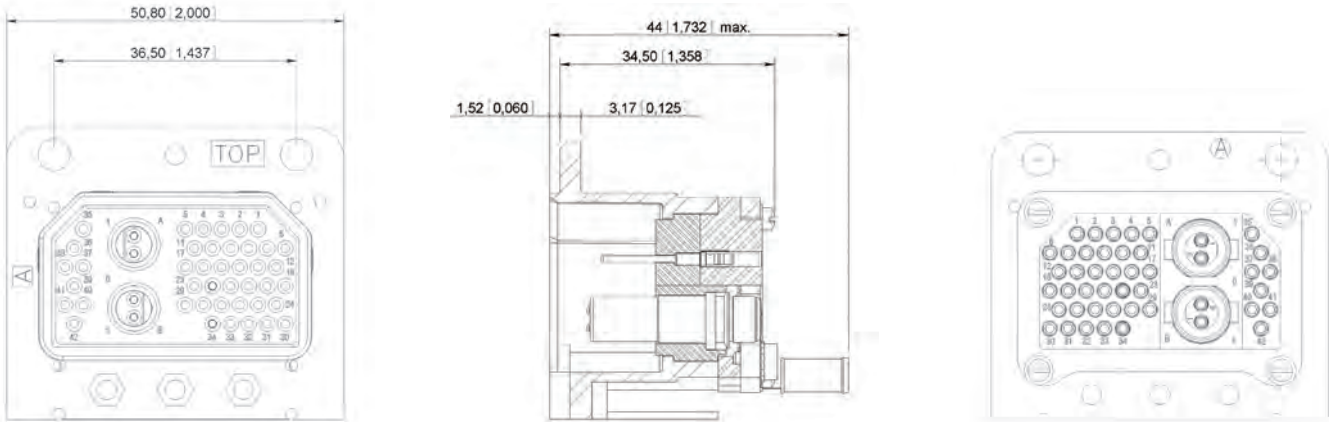

CONTACTS

TWINAX

Contact size	Cable	Pin	Socket	Center contact			Outer body	
				Crimping tool	Positioner	SEL	Crimping tool	Die
B2TP B4TP	F2709/12	/	616090	282281 (M22520/2-01)	282959	7	282293 (M22520/5-01)	282248 OCETA M1001
H4TP H2TP 42B2S	F2709/9	/	616091			8		
B4S B2S	AWG 20 AWG 22 AWG 24	/	616092			7 6 5	Not applicable	
42B2P	AWG 20 AWG 22 AWG 24	616192	/			7 6 5		

HOW TO ORDER ARINC 404 shell type B CONNECTORS

DSX	4	G	13	S	14S	16S	25S	00	01
-----	---	---	----	---	-----	-----	-----	----	----

Series _____

Shell size _____

- 1 : One gang shell
- 2 : Two gang shell
- 3 : Three gang shell
- 4 : Four gang shell

Shell type _____

- G : Receptacle
- H : Plug

Gang A _____

Contact arrangement

See available contact arrangements on pages 6-48 and 6-49

Termination style ⁽²⁺³⁾ _____

- X : Without contacts
- S : Crimp ^(See note 1)
- Z : Fixed solder cup
- K : Wire wrap one levels
- V : Wire wrap two levels
- W : Wire wrap three levels
- Y : PC tail contact

Note 5

Gang B _____

Gang C _____

Gang D _____

Modification code _____

See from page 6-13 to 6-19 for selection

Polarization code ⁽⁴⁾ _____

See page 6-20 for selection

Contact arrangement code table

	00	8	13	26	40	45	57	67	106	32C2	32C4	40C1	C2	C3	C8	D8
Insert for pin contacts	10	12	44	14	16	18	20	22	24	26	40	28	34	36	30	38
Insert for socket contacts	11	13	45	15	17	19	21	23	25	27	41	29	35	37	31	39

NOTES:

- (1) If you need to use reduced crimp barrel contacts, use code X and order contacts separately.
- (2) For C2, C3 and C8 contact arrangements which include coax contacts, use termination code X and order coax contacts separately.
- (3) For mixed layout 32C2, 32C4 and 40C1, the connector is delivered with signal and power contacts but without coax contacts. Order coaxial contacts separately.
- (4) Without polarization code: the connector is delivered with polarizing system unassembled.
Polarization code 00: the connector is delivered without polarizing system.
Polarization code from 01 to 216: the connector is delivered with the polarization hardware assembled as defined by code.
- (5) For contact arrangement 67 and 32C4 with K, V, W or Y termination styles, size 16 contacts are crimp contacts shipped loose with the connector.

TECHNICAL CHARACTERISTICS

MATERIALS

Description	Material	Plating
Shell	Aluminium alloy	Cadmium yellow chromate*
Insert	Thermosetting resin	/
Metallic insert	Aluminium alloy	Cadmium clear chromate
Rear spacer	Silicone rubber	/
Retention clip	Copper alloy	/
Contact	Copper alloy	Gold over nickel under plate
Insert retention plate	Aluminium alloy	Yellow anodized
Insert retention plate with attaching tabs	Aluminium alloy	Cadmium yellow chromate*
Polarizing posts	Stainless steel	/
Polarizing keys	Zinc alloy	Cadmium yellow chromate*
Polarizing keys retention plate	Aluminium alloy	Yellow anodised*
Screws, washers, clinch-nuts	Corrosion resistant steel	/

* More platings are available, see descriptions in modification codes

ELECTRICAL CHARACTERISTICS











They are the same as those described for SAE AS81659 connectors on page 6-7.

MECHANICAL AND ENVIRONMENTAL CHARACTERISTICS

They are the same as those described for SAE AS81659 except that for ARINC 404 connectors no altitude moisture injection test is performed. This test is replaced by a moisture resistance test performed according to method 1002.2 type II of MIL-STD-1344A.

CONTACT ARRANGEMENTS







Pin insert mating side is shown below in the table

Insert name	Number of contacts	DWV	Termination availability	Insert name	Number of contacts	DWV (See note 1)	Termination availability
	8 x #12	1500V - 60Hz	S - Z		45 x #20	1500V - 60Hz	For pin S-Z-Y-K-V-W For socket S-Z-W
	13 x #16	1800V - 60Hz	S - Z For pin Y		57 x #20	1500V - 60Hz	For pin S-Z-Y-K-V-W For socket S-Z-W
	4 x #16 4 x #12	1500V - 60Hz	S - Z		64 x #20HD 3 x #16	1000V - 60Hz	For pin S-Z-Y-K-V-W For socket S-Z-W
	26 x #16	1500V - 60Hz	For pin S-Z-Y-K-V-W For socket S-Z-W		106 x #22	1000V - 60Hz	S-Y-V-W
	40 x #20	1500V - 60Hz	For pin S-Z-Y-K-V-W For socket S-Z-W		1 x #5 (coax) 39 x #20	1500V - 60Hz	For pin S-Z-Y-K-V-W For socket S-Z-W

NOTE:
(1) Dielectric withstanding voltage

CONTACT ARRANGEMENTS

DSX series

Insert name	Number of contacts	DWV	Termination availability	Insert name	Number of contacts	DWV	Termination availability
32C2	 2 x #5 (coax) 30 x #20	1500V – 60Hz 1000V for coax cavity	For pin S-Z-Y-K-V-W For socket S-Z-W	C3	 2 x #7 (coax) 1 x #3	Metallic	S
32C4	 4 x #9 (coax) 4 x #16 24 x #20	1500V – 60Hz 1000V for coax cavity	For pin S-Z-Y-K-V-W For socket S-Z-W	C8	 8 x #9 (coax)	1000V – 60Hz	S
C2	 2 x #1 (coax)	Metallic	S	00			Dummy insert

CONTACTS

SIGNAL AND POWER CRIMP CONTACTS SIZES 22, 20HD, 16 & 12

Contact size	Wire				Pin Radial P/N MIL P/N	Socket Radial P/N MIL P/N	Crimping tool	Positioner	SEL	Ins/Ext Tool
	AWG	Cross section (mm)	Wire outside dia. (inch)	Striping length mm (inch)						
22	22 24 26	0.38 0.21 0.14	1.4 (0.055)	3.05 (0.138)	616200 (MIL 39029/11-144)	616300 (MIL 39029/12-148)	282281 (M22520/2-23)	282970 (M22520/2-23)	4 3 3	282885 (M81969/1-01)
22 reduced crimp barrel	28 30	0.093 0.055	1.4 (0.055)	3.05 (0.138)	616201	616301			5 4	
20HD	20 22 24	0.60 0.38 0.21	1.8 (0.071)	4.0 (0.157)	616210 (MIL 39029/11-145)	616310 (MIL 39029/12-149)		282971 (M22520/2-08)	7 6 5	282886 (M81969/1-02)
20HD reduced crimp barrel	26 28 30	0.14 0.093 0.055	1.8 (0.071)	4.0 (0.157)	616211	616311			6 5 4	
20	20 22 24	0.60 0.38 0.21	1.8 (0.071)	4.0 (0.157)	610220	610325		282972 (M22520/1-02)	4 3 3	282943
20 reduced crimp barrel	26 28 30	0.14 0.093 0.055	1.8 (0.071)	4.0 (0.157)	610221	610321			3 3 2	
16	16 18 20	1.34 0.93 0.60	2.6 (0.102)	6.0 (0.236)	616230 (MIL 39029/11-146)	616330 (MIL 39029/12-150)	282971 (M22520/1-01)		6 5 4	282546 (M81969/1-03)
16 reduced crimp barrel	20 22 24	0.60 0.38 0.21	2.6 (0.102)	6.0 (0.236)	616231	616331			5 5 4	
12	12 14 16	3.18 1.91 1.34	3.4 (0.134)	6.0 (0.236)	616240 (MIL 39029/11-174)	616340 (MIL 39029/12-151)	282579 (M22520/1-11)	8 7 6	282547 (M81969/28-02)	

PC TAIL CONTACTS SIZES 22, 20HD & 20 PC TAIL CONTACTS

PC tail contacts are delivered installed in the connector. Connectors with PC tail contacts have no wire separator. For 32C4 and 67 contact arrangements, size 16 contacts are delivered in crimp termination and are shipped loose with the connector.

Contact size	Contact arrangement	Pin	Socket	Extraction tool	Dimensions mm (inch)				
					Y	B	Dia	D	E
22	106	616206*	616379	282890	6.1/5.3 (0.240/0.209)	6.5 (0.256)	0.6 (0.023)	25.25/25.75 (0.0994/1.013)	1.55/1.75 (0.061/0.069)
			616303		14.4/13.6 (0.567/0.535)	9.4 (0.370)			
			616306*		5.9/6.7 (0.232/0.263)	3.8 (0.149)			
20HD	67	610216*	/	282891	5.75/6.65 (0.226/0.262)	/	0.08 (0.031)	29.20/29.80 (1.149/1.173)	5.40/5.80 (0.212/0.228)
	32C4		6.35/7.55 (0.250/0.297)		29.70/30.30 (1.169/1.192)				
	67	610219			3.35/4.25 (0.131/0.168)	0.75 (0.029)	29.20/29.80 (1.149/1.173)		
	32C4		3.95/5.15 (0.155/0.203)		29.70/30.30 (1.169/1.192)				
20	40-45-57 32C2-40C1	610226*	/	282943	6.10/7.40 (0.240/0.291)	/	0.8 (0.031)	28.55/29.15 (1.124/1.147)	5.40/5.80 (0.212/0.228)

Connectors delivered in the "Y" termination style will be fitted with contacts marked by "***". If you want to use another kind of PC tail contact use termination "x" when ordering the connector and order contacts separately.

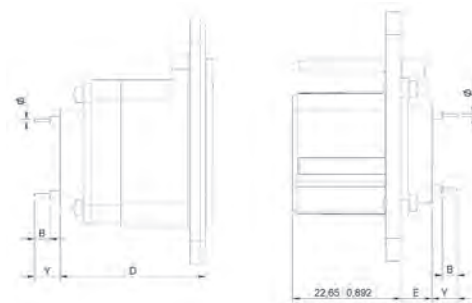

CONTACTS WITH WIRE WRAP POST SIZES 22, 20HD & 20

Wire wrap contacts are delivered installed in the connector. Connectors with wire wrap contacts have no wire separator. For 32C4 and 67 contact arrangements, size 16 contacts are delivered in crimp termination and are shipped loose with the connector.

Contact size	AWG	Contact arrangement	Pin	Socket	Extraction tool	Dimensions mm (inch)					
						D	E	K (1 wrap)	V (2 wrap)	W (3 wrap)	
22	26 28 30	106	610203 (2 wrap levels)	610303 (2 wrap levels)	282948	25.25/25.75 (0.0994/1.013)	1.55/1.75 (0.061/0.069)		10/11 (0.394/0.433)	12.50/13.50 (0.492/0.531)	
			610204 (3 wrap levels)	610304 (3 wrap levels)							
20HD	26 28 30	67	610217 (1 wrap level)	610314 (3 wrap levels)	282948	28.8/29.2 (1.133/1.150)	5.40/5.80 (0.212/0.228)	6.35/7.35 (0.250/0.289)	9.35/10.35 (0.368/0.407)	11.85/12.85 (0.466/0.506)	
		32C4	610215 (2 wrap levels)								610314 (3 wrap levels)
			610214 (3 wrap levels)								
20	26 28 30	40-45-57 32C2-40C1	610228 (1 wrap level)	610324 (3 wrap levels)	282949	28.55/29.15 (1.147/1.124)	5.40/5.80 (0.212/0.228)	6.95/8.25 (0.273/0.325)	9.95/11.25 (0.391/0.443)	12.60/13.8 (0.496/0.543)	
			610225 (2 wrap levels)								
			610224 (3 wrap levels)								

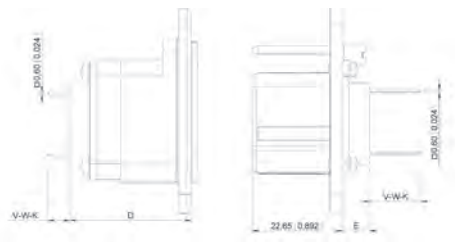

SOLDER CUP CONTACT SIZES 20HD, 20, 16 & 12

Solder cup contacts are fixed contacts delivered installed in the connector. Connectors with solder cup contacts have no wire separator.

Contact size	Contact arrangement	Stripping length	Dimensions mm (inch)		
			A	D	E
20HD	67	2.5 (0.098)	3 (0.118)	29.20/29.80 (1.149/1.173)	5.40/5.80 (0.212/0.228)
	32C4			29.70/30.30 (1.169/1.192)	
20	40-45-57- 32C2-40C1	5 (0.197)	4.5 (0.177)	28.55/29.15 (1.124/1.147)	5.40/5.80 (0.212/0.228)
16	26-67			29.20/29.80 (1.149/1.173)	
	32C4	29.70/30.30 (1.169/1.192)			
12	8-D8			28.55/29.15 (1.124/1.147)	

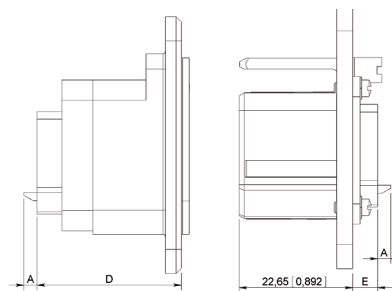

THERMOCOUPLE CONTACT SIZES 22 & 20HD refer to page 6-22

FIBER OPTIC TERMINI SIZES 16 & 12 refer to page 6-23

CONTACTS

COAXIAL CRIMP CONTACT SIZE 1

Contact size	Contact Arrangement	Cable	Pin	Socket	Center contact			Outer body		
					Crimping tool	Positioner	SEL	Crimping tool	Die	Hex
1	C2	UT 141 RG 402	616005	/	Solder contact					
		RG 58 RG 141 KX 15	616005 Right angle	/	Solder contact			282293 (M22520/5-01)	282246 (M22520/5-05)	A
		RG 214 RG 225	/	610108					282247 (M22520/5-61)	A
		SMA	616009	/	SMA termination					

For other cables, please consult Radiall.

COAXIAL CRIMP CONTACT SIZE 3

Contact size	Contact Arrangement	Cable	Pin	Socket	Center contact			Outer body		
					Crimping tool	Positioner	SEL	Crimping tool	Die	Hex
3	C3	RG 214 RG 225	/	610118	Solder			282293 (M22520/5-01)	282247 (M22520/5-61)	A
		UT 141 RG 402	616014	/	Solder contact					

For other cables, please consult Radiall.

Dielectric withstanding voltage at sea level: 1500 V rms

COAXIAL CRIMP CONTACT SIZE 5

Contact size	Contact Arrangement	Cable	Pin	Socket	Center contact			Outer body		
					Crimping tool	Positioner	SEL	Crimping tool	Die	Hex
5	32C2 40C1	RG 58 RG 141 KX 15	610120	610020001	Solder			282293 (M22520/5-01)	282246 (M22520/5-05)	A
		RG 142 RG 223 KX 23	610122	610022001						B
		RG 316 KX 22	610126	610026						
		KX 21 DT	610127	/						
		RG 178	610119	/						
		UT 085	610123	/						
		UT 141	616009	/	Solder					

For other cables, please consult Radiall.

Extraction tool: 282946 (M81969/28-01)

COAXIAL CRIMP CONTACT SIZE 7

Contact size	Contact Arrangement	Cable	Pin	Socket	Center contact			Outer body		
					Crimping tool	Positioner	SEL	Crimping tool	Die	Hex
7	C3	RG 58 RG 141 KX 15	610120	610020001	Solder			282293 (M22520/5-01)	282246 (M22520/5-05)	A
		RG 174 RG 316 RG 188	610126	610026						

For other cables, please consult Radiall.

Extraction tool: 282946 (M81969/28-01)

Dielectric withstanding voltage at sea level: 750 V rms

COAXIAL CRIMP CONTACT SIZE 9

Contact size	Contact Arrangement	Cable	Pin	Socket	Center contact			Outer body		
					Crimping tool	Positioner	SEL	Crimping tool	Die	Hex
9	C8 32C4	RG 316 KX 22	610146	610046	Solder			282293 (M22520/5-01)	282246 (M22520/5-05)	B
		RG 178 KX 21	610147	610047						A
		RG 58 RG 141 KX 15	610140	610040					282236 (M22520/5-45)	B
		RG 142	610149	610049						
		S280W 503-2	/	610044	282281 (M22520/2-01)	DANIELS K345	6	Solder		
		UT 085	610148	/						

For other cables, please consult Radiall.

Extraction tool: 282946 (M81969/28-01)

ACCESSORIES

FILLER PLUGS

Designation	Filler Plugs Part Number
Size 22 (black)	620920
Size 20 (white)	610940
Size 20HD (red)	610941
Size 16 (blue)	620922
Size 12 (yellow)	616923
Size 5 (white)	616802
Size 9 (white)	616802

For Dust caps & backshells please refer to page 6-29 and 6-30

DIMENSIONS

SHELL SIZE 1

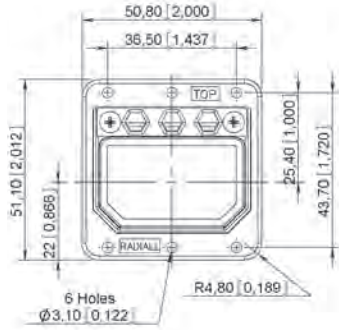

PLUG

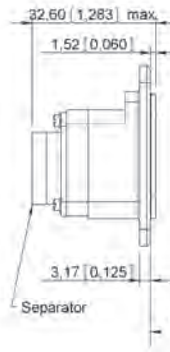

RECEPTACLE

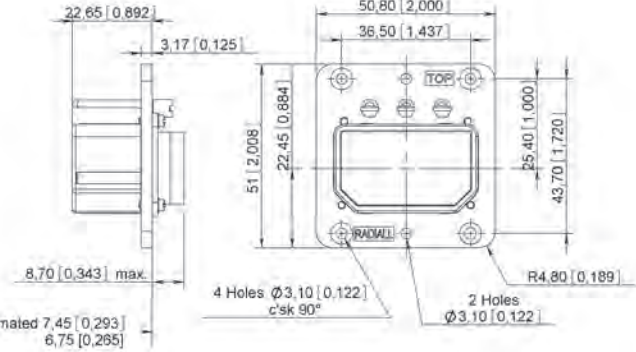

SHELL SIZE 1

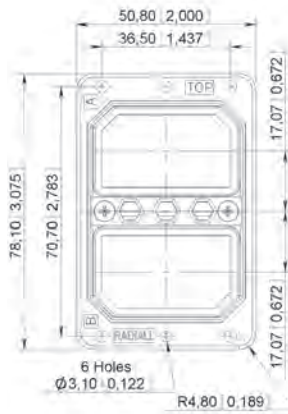

PLUG



RECEPTACLE

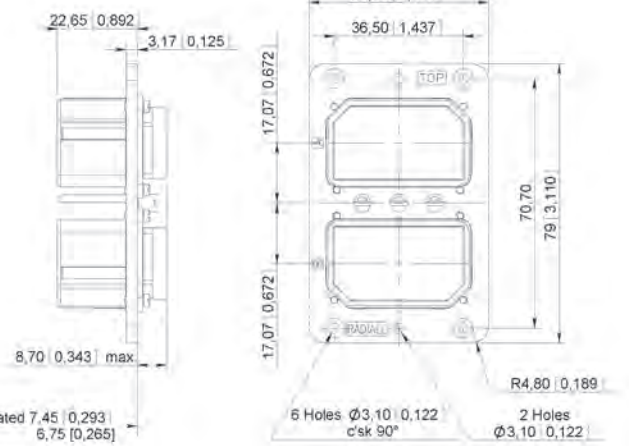

SHELL SIZE 3

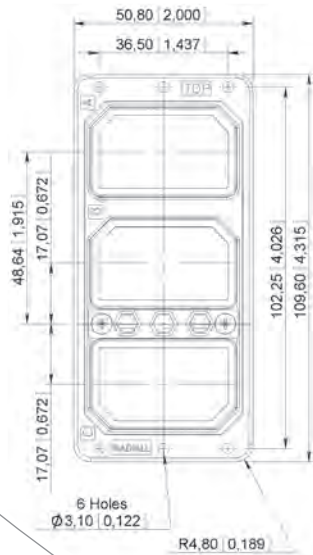

PLUG



RECEPTACLE

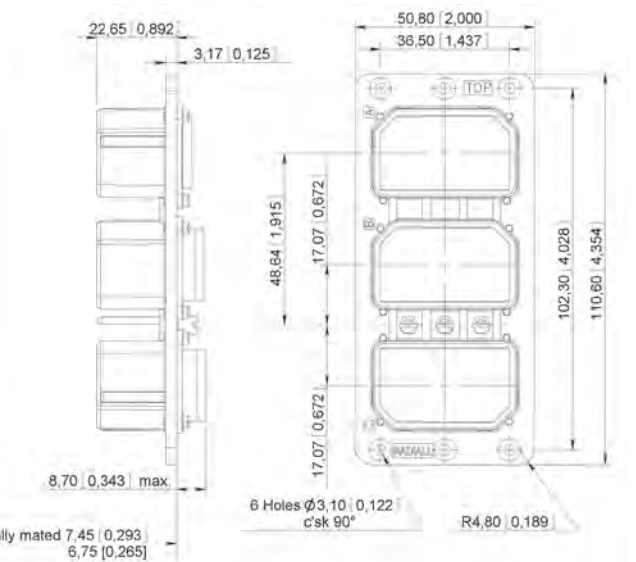

SHELL SIZE 4

PLUG

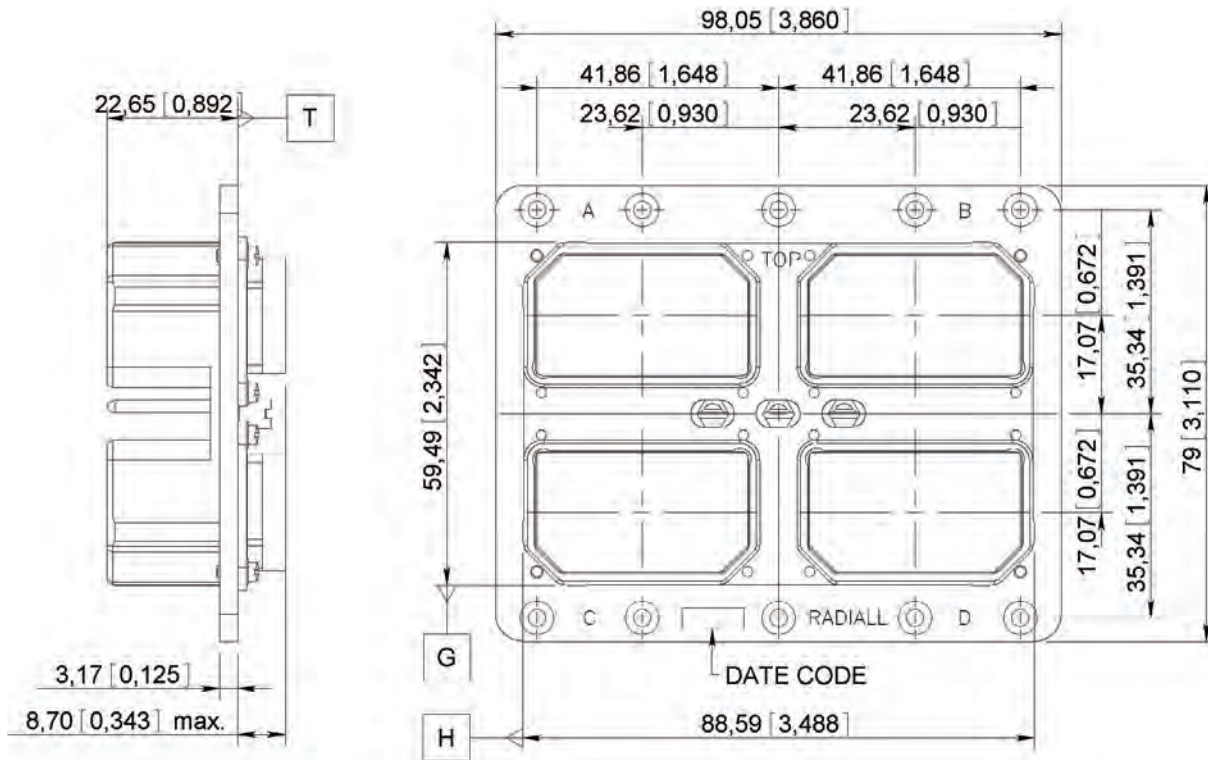

RECEPTACLE

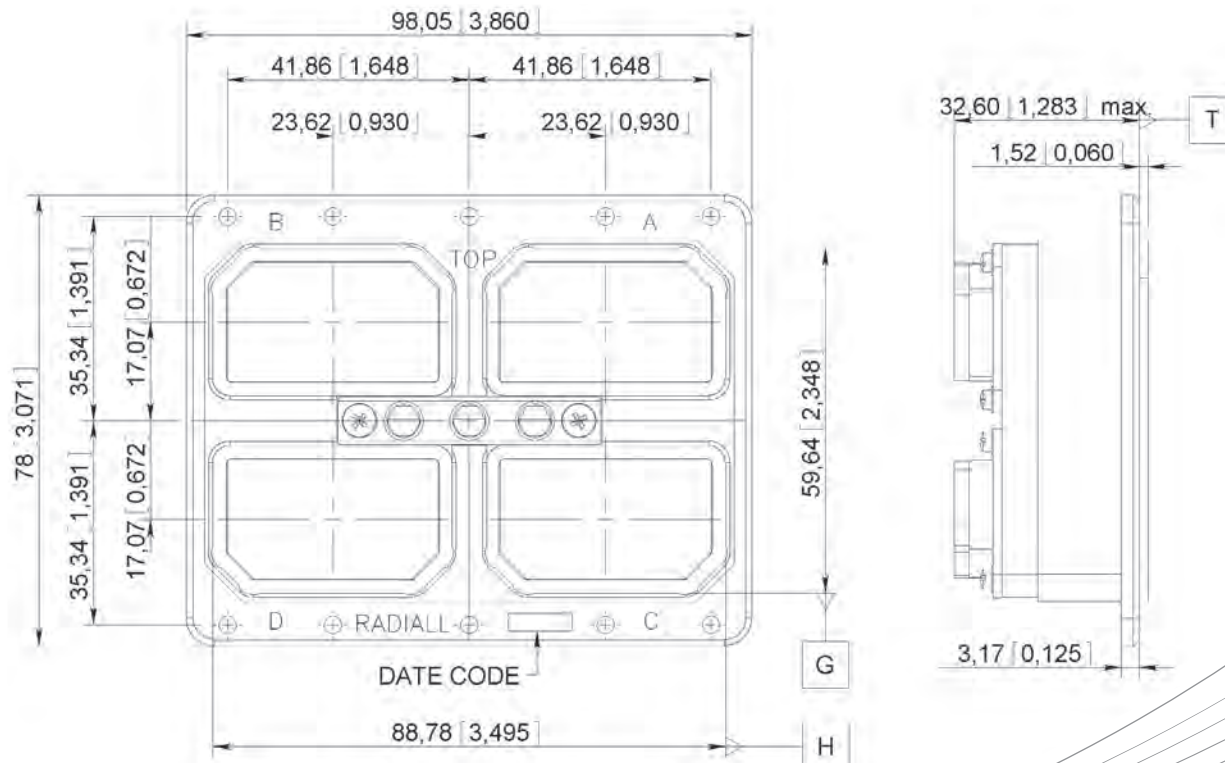

DSX EMI/RFI INTRODUCTION

EMI/RFI acts directly on electronics systems whether by conduction mode through the input or output cables or by radiation (coupling).

Electronics equipments are particularly vulnerable to interferences and can be disturbed or damaged by them. The serious consequences which may result, make it essential to protect such installations.

The first stage in protection is to install the equipment in a shielded cabinet which protects it from some of the interferences; particularly those occurring by radiation. At the connector level that means to use metallic shells so as to have a good mass conduction between the equipment box and the rack.

So as to meet these requirements RADIALL offers plug connectors for rack which are fitted with grounding spring fingers.

DSX SAE AS81659 and DSX Arinc 404 shell type B in sizes 1,2,3, and 4 fitted with grounding fingers are available.

These connectors are interchangeable and intermatable with the standard ones.

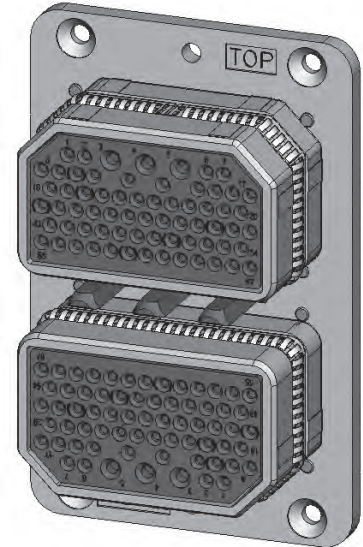

PART NUMBERING

The part numbering system applies to plug shells only.

To establish the part number of a DSX EMI/RFI connector, simply add the letter "G" after the letter which defines the shell type in the DSX SAE AS81659 or Arinc 404 shell type B standard part number.

Examples of part numbers:

DSXN2P**G**S404SS45S0001

DSX2H**G**41S19S0001

TECHNICAL CHARACTERISTICS

The technical characteristics are the same as those of SAE AS81659 and Arinc 404 shell type B connectors except for the following.

Shell to shell conductivity: 2.5mΩ max. Measured according to method 3007 of MIL-STD-1344A.

Shielding effectiveness: >70 dB @ 4GHz. Measured according to method 3008 of MIL-STD-1344A.

MATERIALS

Description	Material	Plating
Grounding spring fingers	Copper alloy	Nickel

ARINC 404 shell type A TECHNICAL CHARACTERISTICS

ELECTRICAL, MECHANICAL & ENVIRONMENTAL CHARACTERISTICS

Refer to SAE AS81659 standards page 6-7.

MATERIALS

Description	Material	Plating
Shell	Aluminium alloy	Cadmium yellow chromate
Insert	Thermosetting resin	/
Metallic insert	Aluminium alloy	Cadmium clear chromate
Rear spacer	Silicone rubber	/
Retention clip	Copper alloy	/
Contact	Copper alloy	Gold over nickel underplate
Insert retention plate	Aluminium alloy	Gold anodized
Screws, washers, clinch-nuts	Corrosion resistant steel	/

HOW TO ORDER ARINC 404 shell type A CONNECTORS

DSX	1	F	18	S	00
-----	---	---	----	---	----

Series _____

Shell size _____
 1 : One gang shell

Shell type _____
 E : Receptacle
 F : Plug

Contact arrangement _____
 See table below and page 6-48

Termination style ⁽²⁺³⁾ _____
 X : Without contacts
 S : Crimp ^(See note 1)
 Z : Fixed solder cup
 K : Wire wrap one levels
 V : Wire wrap two levels
 W : Wire wrap three levels
 Y : PC tail contact

} Note 4

Modification code _____
 See from page 6-13 to 6-19

Contact arrangement code table

	00	8	13	26	40	45	57	67	106	32C2	32C4	40C1	C2	C3	C8	D8
Insert for pin contacts	10	12	44	14	16	18	20	22	24	26	40	28	34	36	30	38
Insert for socket contacts	11	13	45	15	17	19	21	23	25	27	41	29	35	37	31	39

NOTES:
 (1) If you need to use reduced crimp barrel contacts, use code X and order contacts separately.
 (2) For C2, C3 and C8 contact arrangements which include coax contacts, use termination code X and order coax contacts separately.
 (3) For mixed layout 32C2, 32C4 and 40C1, the connector is delivered with signal and power contacts but without coax contacts. Order coaxial contacts separately.
 (4) For contact arrangement 67 and 32C4 with K, V, W or Y termination styles, size 16 contacts are crimp contacts shipped loose with the connector.

Dimensions mm (inch)

CODE	Receptacle shell		Plug shell	
00		4 holes $\varnothing 3.05$ (0.120)		4 holes $\varnothing 3.05$ (0.120)
01		Four 4.40 UNC 3B clinch nuts		Four 4.40 UNC 3B clinch nuts
03		4 mounting slots 4.80 (0.189) wide + four M3 shouldered screws + 4 washers		4 mounting slots 4.80 (0.189) wide + four M3 shouldered screws + 4 washers
04		4 mounting slots 4.80 (0.189) wide + four 4.40 UNC shouldered screws + 4 washers		4 mounting slots 4.80 (0.189) wide + four 4.40 UNC shouldered screws + 4 washers
05		4 holes 3.05 (0.120) dia c'sunk 100°		4 holes 3.05 (0.120) dia c'sunk 100°
06		4 holes 3.05 (0.120) dia c'sunk 82°		4 holes 3.05 (0.120) dia c'sunk 82°
07		4 holes 3.05 (0.120) dia c'sunk 100° + a dust cap		4 holes 3.05 (0.120) dia c'sunk 100° + a dust cap

CONTACT ARRANGEMENTS

They are the same inserts as those used in Arinc 404 shell type B connectors (see page 6-48).

CONTACTS

The contacts used are those shown on page 6-50 to 6-53.

ACCESSORIES

Refer to page 6-53.

DIMENSIONS

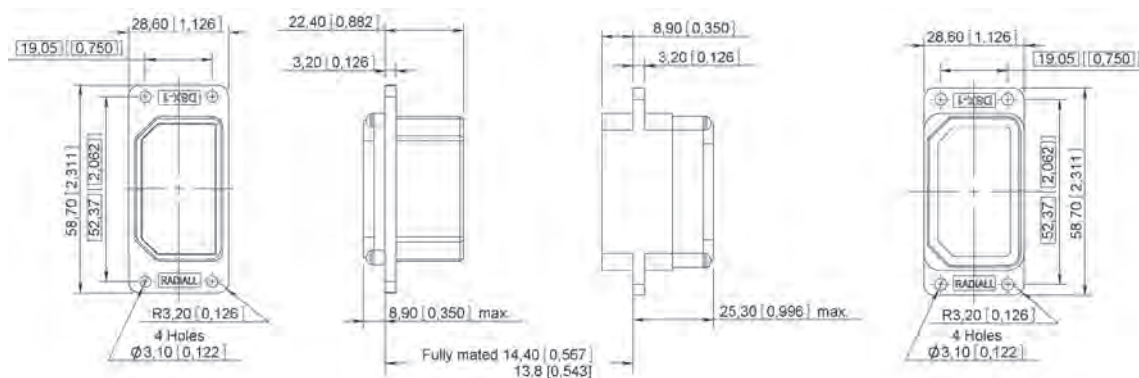

PANEL CUT-OUT

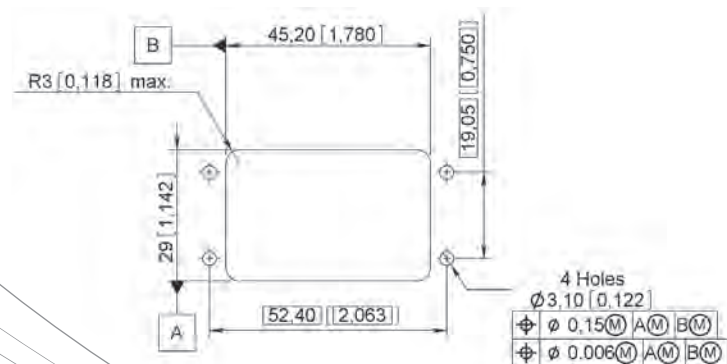

CRIMPING TOOLS

Part number	Mil spec P/N
282281	M22520/2-01
282291	M22520/1-01
282296	DANIELS M300BT
282293	M22520/5-01



POSITIONERS

Part number	Mil spec P/N
282970	M22520/2-23
282971	M22520/2-08
282974	/
282550	Daniels K345
282972	M22520/1-02
282579	M22520/1-11
282557	/



INSERTION / EXTRACTION TOOLS

Part number	Mil spec P/N
282885	M81969/1-01
282886	M81969/1-02
282546	M81969/1-03
282547	M81969/28-02
282943	/
282946	M81969/28-01
282890	/
282892	/
282891	/
282929	/
282945	/
282500	/
282503	/
282504	/
282948	/
282949	/



DIE

Part number	Mil spec P/N
282246	M22520/5-05
282247	M22520/5-61
282248	OCETA M1001
282236	M22520/5-45

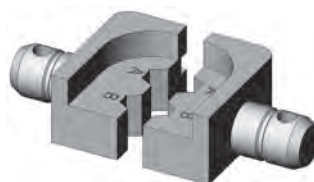

NOTES

DSX series

Area with horizontal dotted lines for taking notes.

NOTES

A series of horizontal dotted lines for taking notes, starting from the top of the page and extending down to just above the footer area.

NOTES

A large area of horizontal dotted lines for taking notes.

NOTES

A series of horizontal dotted lines for writing notes.



AERospace



AUTOMOTIVE



DEFENSE



INDUSTRIAL



INSTRUMENTATION



MEDICAL



SPACE



TELECOM

EUROPE

France - RADIALL SA

101, Rue Ph. Hoffmann
93116 ROSNY sous BOIS (Paris)
Tel.: +33 1 49 35 35 35 - Fax: +33 1 48 54 63 63
E-Mail: info@radiall.com

Finland - RADIALL SF

P.O. Box 202 - 90101 OULU
Tel.: +358 407 522 412
E-Mail: infofi@radiall.com

Germany - RADIALL GmbH

Carl-Zeiss Str. 10 Postfach 200143
D63307 - RÖDERMARK (Frankfurt)
Tel.: +49 60 74 91 07 0 - Fax: +49 60 74 91 07 70
E-Mail: infode@radiall.com

Italy - RADIALL Elettronica S.R.L

Via Concordia, 5 - 20090 ASSAGO MILANO
Tel.: +39 02 48 85 121 - Fax: +39 02 48 84 30 18
E-Mail: infoit@radiall.com
Regional office: Roma

Netherlands - RADIALL B.V.

Hogebrinkerweg 15b - 3871 KM HOEVELAKEN
Tel.: +31 33 253 40 09 - Fax: +31 33 253 45 12
E-Mail: infonl@radiall.com

Sweden - RADIALL A.B.

Sjöängsvägen 2 - SE-192 72 SOLLENTUNA (Stockholm)
Tel.: +46 844 434 10 - Fax: +46 875 449 16
E-Mail: infose@radiall.com

U.K. - RADIALL Ltd

Ground Floor, 6 The Grand Union Office Park,
Packet Boat Lane
UXBRIDGE Middlesex UB8 2GH (London)
Tel.: +44 1895 425 000 - Fax: +44 1895 425 010
E-Mail: infouk@radiall.com

NORTH AMERICA

USA - RADIALL USA, Inc.

8950 South 52nd Street, Suite 401
Tempe, Arizona 85284
Tel.: +1 480 682 9400 - Fax: +1 480 682 9403
E-Mail: infousa@radiall.com

ASIA

China - SHANGHAI RADIALL Electronic Co., Ltd

N° 390 Yong He Road 200072 - SHANGHAI
Tel.: +86 21 66 52 37 88 - Fax: +86 21 66 52 11 77
E-Mail: infosh@radiall.com

Japan - NIHON RADIALL

Shibuya-ku Ebisu 1-5-2, Kougetsu Bldg 405
TOKYO 150-0013
Tel.: +81 3 3440 6241 - Fax: +81 3 3440 6242
E-Mail: infojp@radiall.com

HongKong - RADIALL Electronics Ltd

Flat D, 6/F, Ford Glory Plaza,
37-39 Wing Hong Street
Cheung Sha Wan
KOWLOON HONG KONG
Tel: +852-2959-3833 - Fax: +852-2959-2636
E-Mail: infohk@radiall.com

RADIALL India private limites

25 D, II Phase, Peenya Industrial Area
BANGALORE 560058
Tel.: +91 80 83 95 271 - Fax: +91 80 83 97 228
E-Mail: infoin@radiall.com

ALSO REPRESENTED IN

Australia	Hungary	Poland
Austria	Indonesia	Russia
Belgium	Israel	Singapore
Brazil	Korea	Spain
Czech Republic	Latvia	Switzerland
Denmark	Lithuania	Taiwan
Estonia	Malaysia	Thailand
Greece	Norway	Vietnam
	Philippines	South Africa

For the above countries, please contact the local agent or RADIALL at info@radiall.com

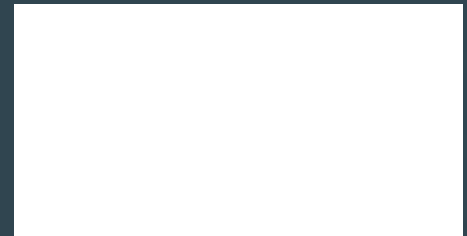

D7P001CE