

Low Profile Transition Boots

- Helashrink 412H Series, side breakout

This style provides connector cable strain relief and is used in conjunction with a circular grooved adapter.



412H622-625 Series supplied / fully recovered.

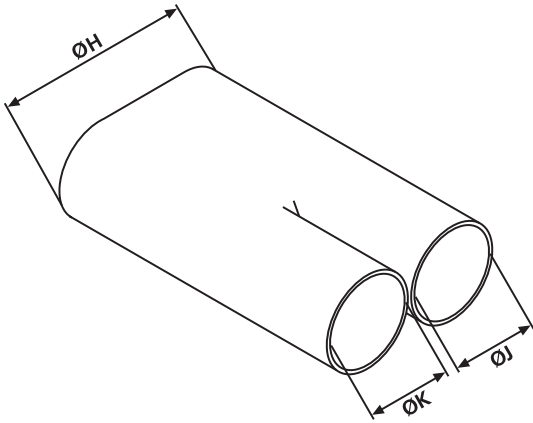

a: Expanded form (supplied)

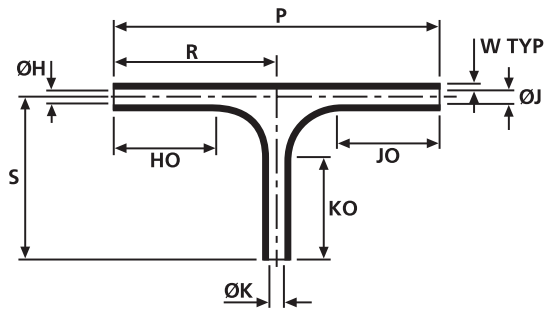

b: Fully recovered form (after heating)

Sizes and Type Table

Type	ØH min. a	ØH max. b	ØJ/K min. a	ØJ/K max. b	HO/JO/KO ± 10%	P nom	W nom	R/S nom
412H622	19.8	6.6	13.2	6.6	25.4	80.7	1.0	40.3
412H623	34.2	11.4	22.8	6.6	41.1	120.3	1.3	60.1
412H624	60.1	20.0	40.1	20.0	63.5	175.7	1.5	87.8
412H625	83.3	33.2	54.8	33.2	88.9	242.3	1.7	121.1

All dimensions in mm. Subject to technical changes.

Combinations "On request"

Adhesive	Material		
	9	8	6
TSA-200	√	√	√
WM250	√	√	√
W8	√	√	√
W24	√	√	√
V9500	√	√	√
HMT200A	√	√	√
Without Adhesive	√	√	√

Standard combinations

Article-No.	Type
422-40000	412H622-9
422-40100	412H623-9
422-40200	412H624-9
422-40300	412H625-9

Low Profile Transition Boots

• Helashrink 492H Series, 1 to 2 cables

This style provides strain relief, sealing and mechanical protection on cable harness breakouts or transitions.



492H412-415 Series supplied / fully recovered.

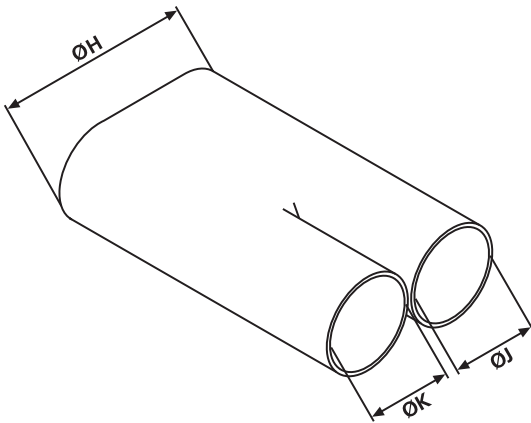

a: Expanded form (supplied)

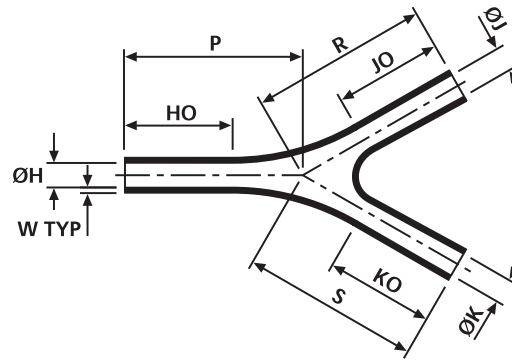

b: Fully recovered form (after heating)

Sizes and Type Table

Type	ØH min. a	ØH max. b	ØJ/K min. a	ØJ/K max. b	HO/JO/KO +/- 15%	W nom	P/R/S nom
492H412	19.8	6.6	13.2	6.6	25.4	1.0	40.6
492H413	34.2	11.4	22.8	11.4	41.1	1.3	62.9
492H414	60.1	20.0	40.1	20.0	63.5	1.5	94.7
492H415	83.3	33.2	54.8	33.2	49.7	1.7	133.8

All dimensions in mm. Subject to technical changes.

For Material / Adhesive selection and other information please refer to page 10.

Combinations "On request"

Adhesive	Material		
	9	8	6
TSA-200	√	√	√
WM250	√	√	√
W8	√	√	√
W24	√	√	√
V9500	√	√	√
HMT200A	√	√	√
Without Adhesive	√	√	√

Standard combinations

Article-No.	Type
422-50000	492H412-9
422-50101	492H413-9
422-50202	492H414-9
422-50302	492H415-9