

Description

Single pole circuit breaker type 437 or single/two pole isolation switches types 921/922 featuring an additional electronic function module which limits the duration of the supply to the remote disconnect and reconnect coils, avoiding damage in the event of unusual operating circumstances. Available with undervoltage monitoring option to protect batteries from the effects of deep discharge, status output for undervoltage, auto reset feature.

Typical applications

Battery and cable protection for all types of vehicle (including electric), battery powered systems.

Ordering information

Type No.

E-1073 control unit for types 921/922 and 437 with remote control

Voltage rating

0 DC 12 V

1 DC 24 V

Control mode

1 ON/OFF control input

00 without additional function

02 with undervoltage protection and status output

12 with autoreset, undervoltage protection and status output (921/922 only)

2 ON and OFF buttons

33 with control current supply and ON/OFF test input

Circuit Breaker/Isolation Switch

437 single pole circuit breaker (2-pole upon request)

921 single pole battery isolation switch

922 double pole battery isolation switch

Enclosure design (optional)

blank = without housing

B3 moulded housing, for use with single pole devices

B32 moulded housing, for use with double pole device

B34 moulded housing, external operating knob, for use with double pole devices (not with auto reset)

B35 moulded housing, external operating knob, for use with single pole devices (not with auto reset)

Terminal design

K12 flat screw terminals angled 90°, for single pole version

K60 straight flat screw terminals, for single pole version, without housing

K72 flat screw terminals angled 90°, for double pole version

Characteristic curve (type 437 only)

06 fast magnetic trip

07 delayed magnetic trip (standard)

Auxiliary contacts

Si01 one N/C, two N/O (one N/C, one N/O with autoreset option)

Current ratings

437: 40, 50, 63, 80, 100, 120, 160, 200, 240A

921: 240 A

922: 120 A

E-1073 - 1 1 02 - 437 - B3 - K12 - 07 - Si01 - 240 A ordering example

The exact part number required can be built up from the table of choices shown above. Ordering references for optional features should be omitted if not required.

Technical data of switch or circuit breaker

see types 437, 921 or 922

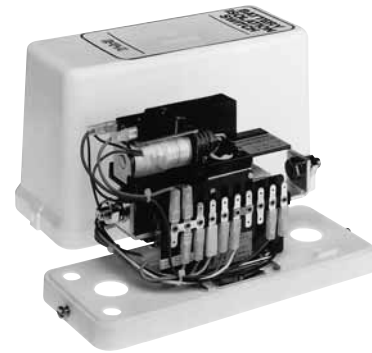

E-1073-437

Technical data – Electronic module

Voltage rating	DC 12 V	DC 24 V
Voltage rating range	ON 10.3 - 16 V	18 - 32 V
	OFF 9 - 16 V	16 - 32 V
Correct switching performance is not guaranteed if the voltage falls below the minimum value.		
Temperature range electronic control unit	-40...+80 °C (-40...+176 °F)	
Operating current	ON approx. 30 A	approx. 15 A
	OFF approx. 10 A	approx. 20 A
Excitation time	ON typically 100 ms	
	OFF typically 20 ms	
Switching frequency	0.1 Hz max.	
Power consumption of electronic control unit	typically < 1 mA (when switched off or button operated)	
Control inputs	E-1073-.1.: »E/A« (ON/OFF), »U-AUS« (undervoltage protection OFF), »A-W« (auto reset)	
	E-1073-.2.: »T-EIN« (button ON), »T-AUS« (button OFF)	
voltage	ON (high)	max. 32 V
	OFF (low)	> 8 V
power consumption	DC 12 V:	typically 1 mA
	DC 24 V:	typically 5 mA
EMC	according to DIN 40839/ISO 7637	
Reverse polarity protection	If polarized incorrectly, the Battery Isolation Switch will operate immediately. The circuit breaker will trip after a few seconds.	
Undervoltage protection switching thresholds	optional with E-1073-.1..	
	DC 12 V:	11.0 V ± 0.2 V
hysteresis	DC 24 V:	22.8 V ± 0.2 V
	trip time	typically 0.5 V
Undervoltage status output transistor output current load	typically 40 sec	
	»UST«, optional with E-1073-.1.. minus switching corresponding to 2 W lamp load, short-circuit proof	
Automatic reset »A-W«, (optional with E-1073-.1.., with series 921/922 only)	Reset after mechanical disconnection is provided by the integral electronic control after approx. 100 ms.	
Control current supply »+US2«, with E-1073-.2.. for T-EIN/T-AUS	May be connected to 20 control inputs. Noise-voltage proof, short-circuit proof	
Terminals control terminals	blade terminals 6.3x0.8 mm	
Mass, with circuit breaker or isolation switch	approx. 2,000 g without enclosure approx. 2,500 g with enclosure	

Features

- Multiple functions in one unit
 - High performance circuit breaker providing battery and cable protection from overloads and short-circuits.
 - Master switch for ON/OFF operation
 - Electrical remote control
 - Undervoltage protection with status output
 - Auxiliary contacts (e.g. for generator disconnection)
 - Active reverse polarity protection of the entire vehicle electrical system
- Current ratings to 240 A (higher voltage ratings to special order)
- Closed-circuit current consumption < 1 mA

Technical description

E-T-A circuit breaker/battery isolation switches combined with electronic control unit E-1073 will meet a wide range of requirements.

Circuit breaker/battery isolation switches

The main switching contacts will open the plus, the minus or both poles according to model and application.

- **Series E-1073-....437**
Single pole thermal-magnetic circuit breaker for current ratings up to 240 A, to protect the vehicle electrical system from overloads and short circuits.
- **Series E-1073-....921**
Single pole battery isolation switch for current ratings up to 240 A.
- **Series E-1073-....922**
Double pole battery isolation switch for current ratings up to 120 A.

Electronic control unit

An electronic control unit enables the basic on/off function and two additional functions. The system voltage is connected across terminals +UB/-UB to provide the supply to the control unit and a feed is taken from +US1 for the remotely sited operating switch(es). The quiescent current drain is typically less than 1 mA, with a short duration excursion during excitation of the ON/OFF coils.

Basic function

Switch ON/OFF

Operation of the ON control switch will energise the switch-on coil for approximately 100 ms causing the main switching contacts to latch closed. Operation of the OFF control switch will cause the disconnect coil to trigger the release of the switching mechanism within approximately 20 ms. Both coil circuits are current limited to prevent damage through overheating.

Manual operation

An optional external operating knob is available to provide manual control in addition to electrical ON/OFF operation.

Reverse polarity protection

In the event of reverse polarity connection, the electronic control unit will immediately operate the battery switch to isolate the entire electrical system. The circuit breaker will trip after a short delay to protect the operating coils and must be re-set once the fault has been corrected.

Control functions

Type 1 E-1073-.1.. with ON/OFF switch

ON/OFF control switch input (»E/A«)

The battery isolation switch can be operated on or off by an external control switch to plus.

Undervoltage protection (optional)

This optional feature protects the battery from deep discharge should electrical loads be left on.

The battery is automatically disconnected whenever the voltage falls below a critical value for more than 40 s. The unit is reset by operation of the control switch. Sustained undervoltage after reconnection causes the unit to disconnect again after approx. 40 s.

Overriding the undervoltage protection (»U-AUS«)

Undervoltage protection may be overridden if required by connecting control output »U-AUS« to plus terminal or terminal 15.

Undervoltage status output (»UST«)

Undervoltage is signalled immediately via the minus-switching, short-circuit proof transistor output (2 W lamp load).

Auto reset (»A-W«), optional with series 921 and 922

Immediate reset after unwanted mechanical disconnection (e.g. upon excessive vibration) is provided by the integral electronic control.

Type 2 E-1073-.2.. with ON/OFF button

ON/OFF control inputs (»T-ON/T-OFF«)

ON/OFF function is provided by two external switches with a central control function, i.e. several systems can be operated simultaneously.

Additional control current supply (»+US2«)

If several circuit breakers/battery isolation switches are operated in parallel, switches can be supplied with control current from any of the electronic control units available. This power source is short-circuit proof, protected from noise voltages and will operate for 20 inputs.

Additional control input »ON/OFF Test« (»E/A«)

This control input can be used for maintenance purposes. The battery isolation switch is switched on when plus voltage is applied, and switched off when plus voltage is removed.

Note

The circuit breaker should be in the OFF condition when connecting or replacing the battery.

Observe instructions for installation!

Dimensions

E-1073-...-437/-921-...-K12-...

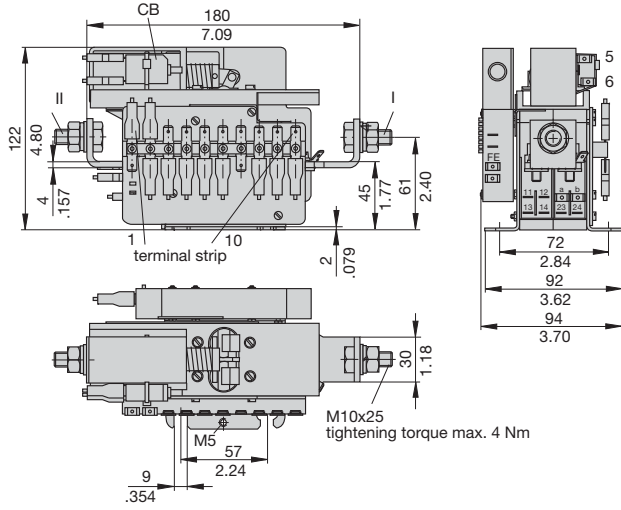

E-1073-...-437/-921-...-K60-...

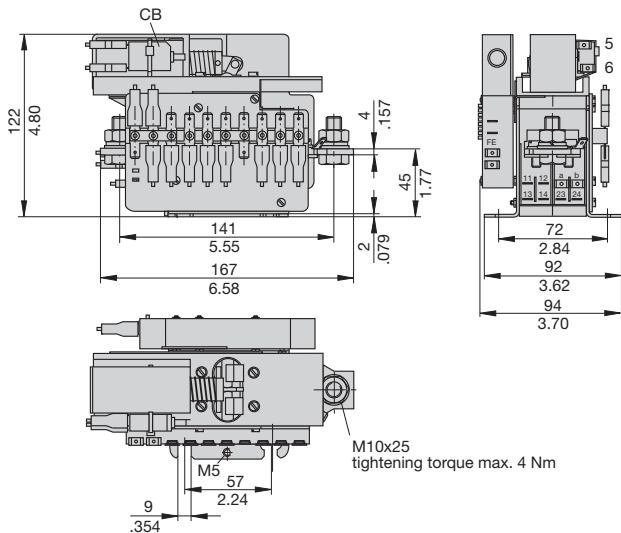

E-1073-...-922-...-K72-...

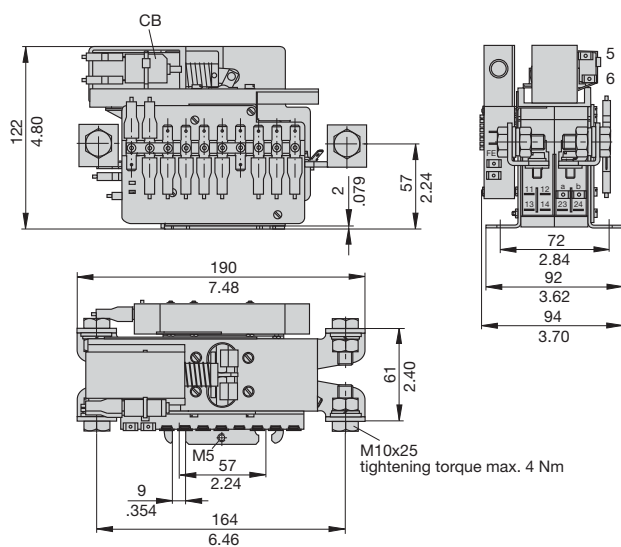

Dimensions – Enclosures

-B3, single pole

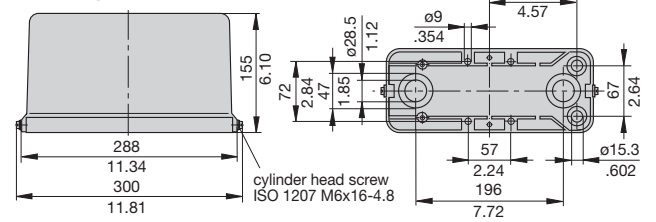

-B35, single pole with operating knob

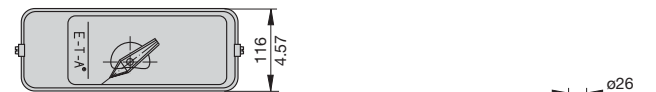

-B32, double pole

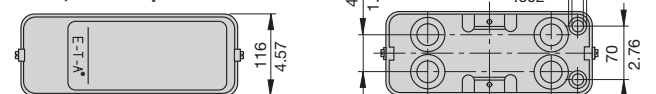

-B34, double pole with operating knob

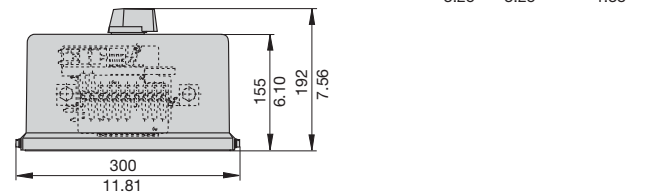

Connection diagrams

E-1073-1...-437/-921/-922 control function ON/OFF switch

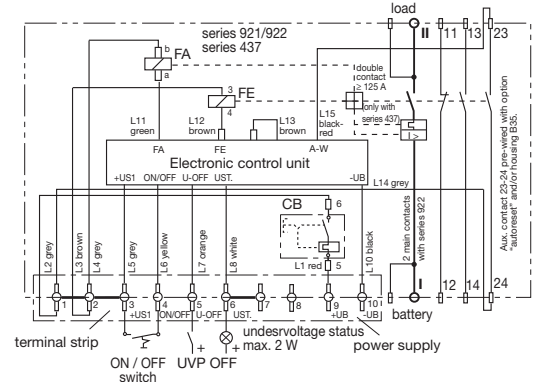

E-1073-2...-437/-921/-922 control function ON/OFF button

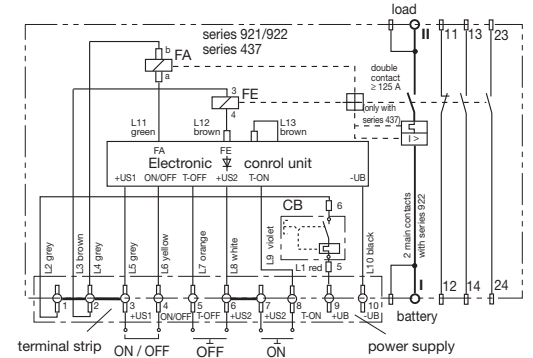

This is a metric design and millimeter dimensions take precedence (mm/inch)

Typical applications

For road vehicles, e.g. buses and coaches Series E-1073-1102-437-B3-K12-07-Si01-240 A

In this application, the E-T-A combined battery switch/circuit breaker has several functions:

- High performance circuit breaker rated at 240 A, providing battery and cable protection from overloads and short circuits.
- Isolation switch, for ON/OFF operation (e.g. for main system disconnection).
- Remote control via external, low-current circuit.
- Undervoltage protection from battery deep discharge should electrical loads be left on.
- Early under voltage signalisation via a warning lamp (undervoltage status output), located as required.
- Undervoltage operation can be overridden if required.
- Auxiliary contact to disconnect the generator field.
- Reverse polarity protection through immediate disconnection of the entire vehicle electrical system if the battery is incorrectly connected.

These functions allow the number of components and cables required to be reduced, with significant space and weight saving benefits.

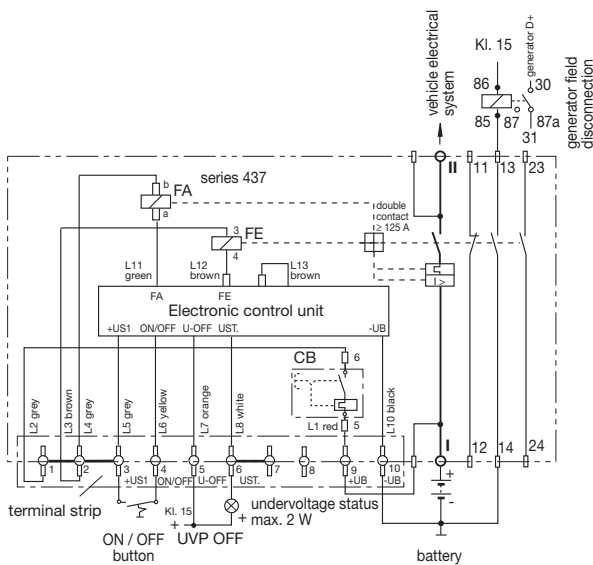

For rail vehicles, e.g. underground carriages Series E-1073-1233-437-K60-06-Si01-200 A

In this application, the E-T-A combined battery switch/circuit breaker has two functions:

- High performance circuit breaker providing battery and cable protection from overloads and short circuits.
- Isolation switch between battery and loads.

In this application, an ON/OFF remote control switch can be provided in both the first and last carriages. This will enable all batteries to be disconnected from the power distribution system by the operation of one control, irrespective of its location. In the same way, all batteries can be re-connected by the operation of a single control switch.

This is extremely helpful during coupling/de-coupling of carriages for example. In addition the E/A test input permits the operation of individual battery switch/circuit breakers during maintenance.

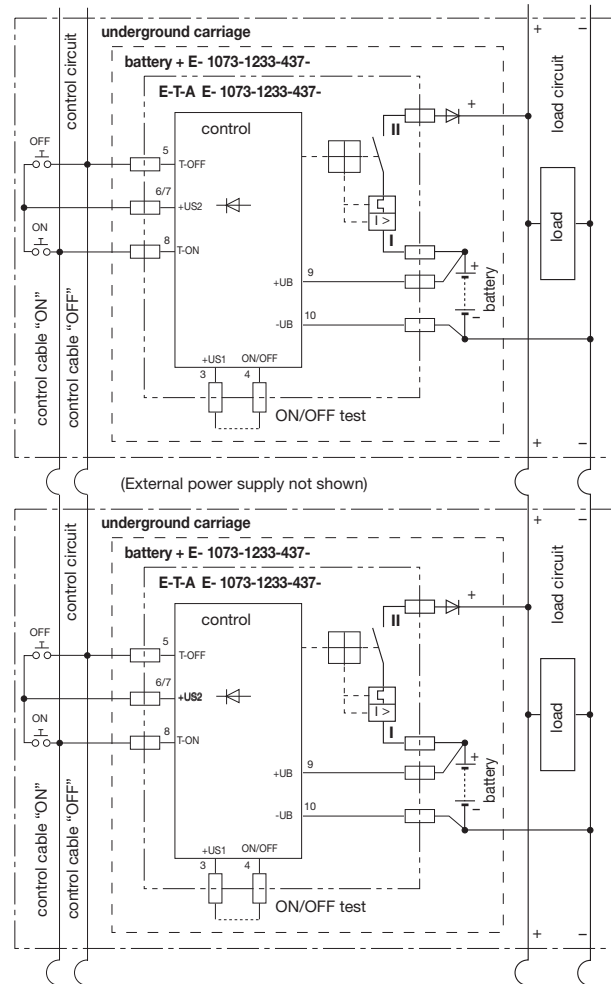

This is a metric design and millimeter dimensions take precedence ($\frac{\text{mm}}{\text{inch}}$)

All dimensions without tolerances are for reference only. In the interest of improved design, performance and cost effectiveness the right to make changes in these specifications without notice is reserved. Product markings may not be exactly as the ordering codes. Errors and omissions excepted.