

Description

Single pole remote control circuit breaker (RCCB), temperature compensated, either with or without auxiliary contacts, and featuring a bimetal actuator which trips the circuit breaker mechanism within a specified time under overcurrent conditions. The switching contact latching system is operated by a bi-stable linear motor controlled by electronic circuitry incorporated within the device. Remote control is achieved through the use of a conventional single pole manually operated aircraft style thermal circuit breaker which connects the control input of the RCCB to ground.

With the control circuit breaker (ICU) in the ON position, the RCCB will switch on. When the control circuit breaker is switched off, the RCCB will change to the OFF condition. If power is applied to a previously de-energised RCCB, the device will adopt the same switching status as the control circuit breaker.

If the RCCB trips thermally in the event of a load circuit fault, the electronic circuitry will also cause the control circuit breaker to trip, thereby providing a visual indication through the position of the circuit breaker actuator.

Approved to MIL-PRF-83383.

Typical applications

Aircraft electrical systems and equipment, and other high performance applications.

Ordering information

Type No.

4930 single pole remote control circuit breaker (RCCB)

Variation

- 01 standard, with auxiliary contacts
- 02 with modified terminal barrier and auxiliary contacts
- 03 standard, without auxiliary contacts
- 04 with modified terminal barrier but without auxiliary contacts

Current ratings

5...100 A

4930 - 01 - 5 A ordering example

I _N /A	E-T-A part number	MIL part number	E-T-A part number	MIL part number
5	4930-01-5A	M83383/02-01	4930-03-5A	M83383/01-01
7.5	4930-01-7.5A	M83383/02-02	4930-03-7.5A	M83383/01-02
10	4930-01-10A	M83383/02-03	4930-03-10A	M83383/01-03
15	4930-01-15A	M83383/02-04	4930-03-15A	M83383/01-04
20	4930-01-20A	M83383/02-05	4930-03-20A	M83383/01-05
25	4930-01-25A	M83383/02-06	4930-03-25A	M83383/01-06
35	4930-01-35A	M83383/02-07	4930-03-35A	M83383/01-07
40	4930-01-40A	M83383/02-08	4930-03-40A	M83383/01-08
50	4930-01-50A	M83383/02-09	4930-03-50A	M83383/01-09
60	4930-01-60A	M83383/02-10	4930-03-60A	M83383/01-10
75	4930-01-75A	M83383/02-11	4930-03-75A	M83383/01-11
80	4930-01-80A	M83383/02-12	4930-03-80A	M83383/01-12
100	4930-01-100A	M83383/02-13	4930-03-100A	M83383/01-13

Approvals

MIL-PRF-83383



4930 (RCCB)

Technical data (T_A = 25 °C, U_e = DC 28 V or AC 115V/400 Hz)

Operating data LINE	(see also MIL-PRF-83383)
Voltage ratings U _e (operating voltage range)	AC 115 V 400 Hz (AC 104...126 V); DC 28 V (DC 18...36 V)
Current rating range I _N	5...100 A (see ordering information)
Bias current	typically 2.5 mA at DC 28 V typically 25 mA at AC 115 V
Switching current/ switching period for internal linear motor	typically 3.4 A / 28 ms at DC typically 2.8 A / 17 ms at AC
Optical indication ON/OFF	status indicator (near terminal A1)
Load circuit LOAD	
Current rating range I _N	5...100 A (see ordering information)
Interrupting capacity	DC 28 V: 6,000 A AC 115 V 400 Hz: 3,600 A
Voltage drop at I _N	see table 1 (standard current ratings and typical voltage drop values)
Overload disconnection	see table 2 (typical time/current characteristics)
Trip limits	see table 2
Control circuit ICU	
ICU	Indicator/Control Unit thermal circuit breaker 0.5 A
Trigger current for ICU ("TRIP FREE"-mode) / duration	approx. 3.2 A / 5 s max
Control voltage U _{ICU} RCCB "OFF" (ICU open)	Limits: U _{ICU} > typ. 2 V (> 1.5 V between -54...+71 °C / -65...+160 °F)
RCCB "ON" (ICU closed)	U _{ICU} < typ. 0.6 V (< 0.2 V between -54...+71 °C / -65...+160 °F)
Control current I _{ICU}	typically 0.4 mA
Additional control units	one relay contact or one ON/OFF switch is applicable (see application note ICU)
ON/OFF-cycling time (e. g. additional relay contact in ICU circuit)	ON > 80 ms / OFF > 80 ms
Signal output AUX	
Auxiliary contacts	change over contacts S1 - S2 is open, when RCCB main contact is open
Voltage ratings	DC 28 V, AC 115 V (400 Hz)
Current ratings	resistive load: 3 A / inductive load 1.5 A lamp load: 0.5 A

Technical data ($T_A = 25\text{ }^\circ\text{C}$, $U_e = \text{DC } 28\text{ V}$ or $\text{AC } 115\text{V}/400\text{ Hz}$)

General data

Typical life endurance	50,000 operations at I_N (inductive or resistive)
Ambient temperature	-54...+71 $^\circ\text{C}$ (-65...+160 $^\circ\text{F}$)
Dielectric strength (IEC 60664 and 60664A)	test voltage between main terminals AC 1,500 V main terminal to mounting area AC 1,500 V
Insulation resistance	> 100 M Ω (DC 500 V)
Vibration (sinusoidal)	10 g (55-2000 Hz), $\pm 0.76\text{ mm}$ (10-55 Hz) to MIL-STD 202, method 204, condition C
Vibration (random)	10-2000 Hz 0.15 g^2/Hz , rms value 13.5 g; 5 h/axis loaded with 0.9 I_N
Shock	25 g (11 ms, half sinusoidal) to MIL-STD 202, method 213, condition J ISO 7137 (RTCA/DO-160 C, part 7)
Corrosion	48 hours at 5 % salt mist to MIL-STD 202, method 101, condition B ISO 7137 (RTCA/DO-160 C, part 14, category S)
Humidity	240 hours at 95 % RH to MIL-STD 202, method 106/ISO 7137 (RTCA/DO-160 C, part 6, category B)
Sand and dust	to MIL-STD 202, method 110, test condition A
Fungus	to MIL-STD 810 D, method 508.3, 28 days
Altitude	$\leq 15,000\text{ m}$ above sea level
EMI requirements	to MIL-STD 461, class 1 D
Mass	5...25 A approx. 315 g 35...100 A approx. 319 g
Dimensions	max. 82.55 x 31.9 x 108.2 mm (max. 3.25 x 1.256 x 4.26 inch)
Terminals, connections	see table 3

Table 1

Standard current ratings and typical voltage drop values

Current ratings (A)	Voltage drop at rated current (mV)	Current ratings (A)	Voltage drop at rated current (mV)
5	450	40	225
7.5	360	50	225
10	347	60	225
15	225	75	225
20	225	80	225
25	225	100	225
35	225		

Table 2

Typical time/current characteristics

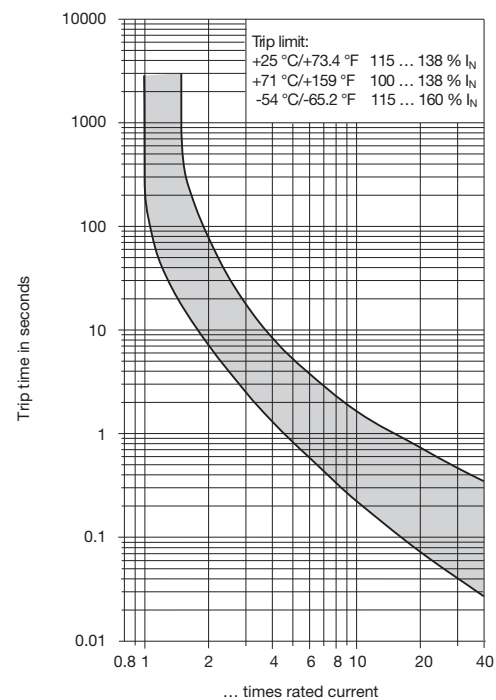

Table 3

Terminals, connections

Current rating (A)	5...25	35...100
Thread A	0.190-32 UNF-2A	0.250-28 UNF-2A
Mounting torque	2 Nm	4.1 Nm
B (mm/in.)	12.7/.500	15.5/.610
C (mm/in.)	12.7/.500	15.5/.610
Nut	AN315-3R	AN315-4R
Lock washer	MS 35338-43	MS 35338-44
Flat washer	NAS 1149F0322P	NAS 1149F0463P

Dimensions

Type 4930-01 (M 83383/02)
-03 (M 83383/01)

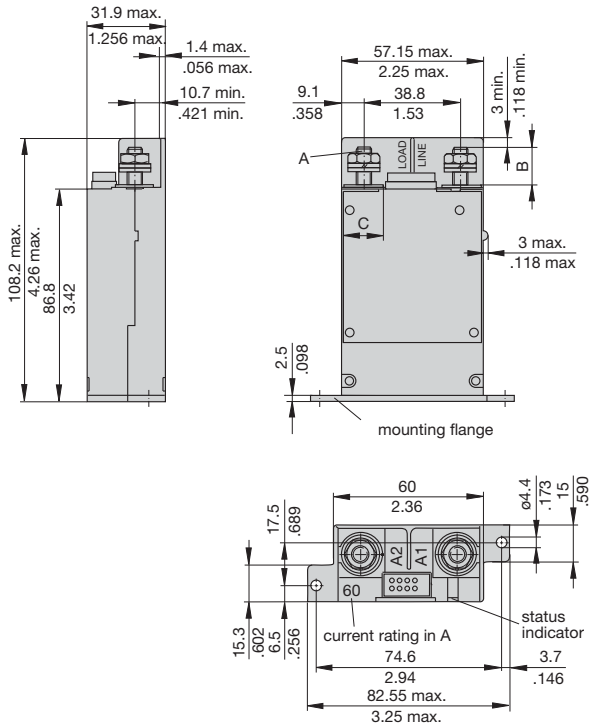

Type 4930-02/-04

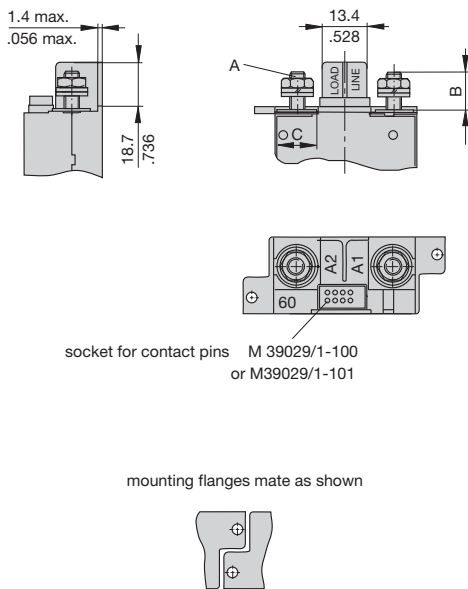

Terminal configuration

Pin no.	Terminal	Description
A1	LINE	power supply DC 28 V, AC 115 V / 400 Hz
A2	LOAD	load is connected to ground GND
3	ICU	control input, when grounded, RCCB = "ON"
4	Backup power	AC 115 V / 400 Hz (same AC phase as LINE) or DC 28 V
5A, 5B	GND	ground potential
6		internally connected to 3
S1, S2, S3	AUX	auxiliary change over contacts

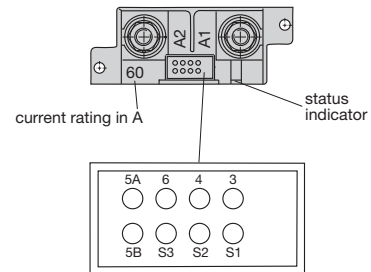

This is a metric design and millimeter dimensions take precedence ($\frac{\text{mm}}{\text{inch}}$)

Internal Connection diagrams

Type 4930-01/ -02 (with auxiliary contacts)

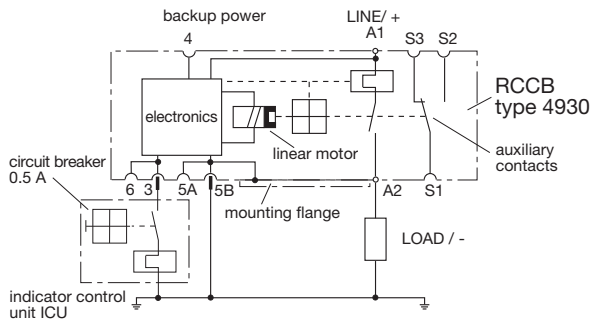

Type 4930-03/ -04 (without auxiliary contacts)

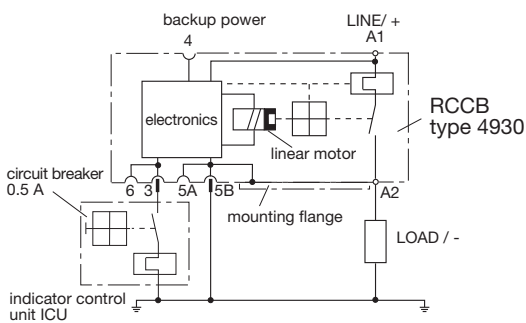

Application note (ICU)

Type 4930-01/ -02 (with auxiliary contacts)

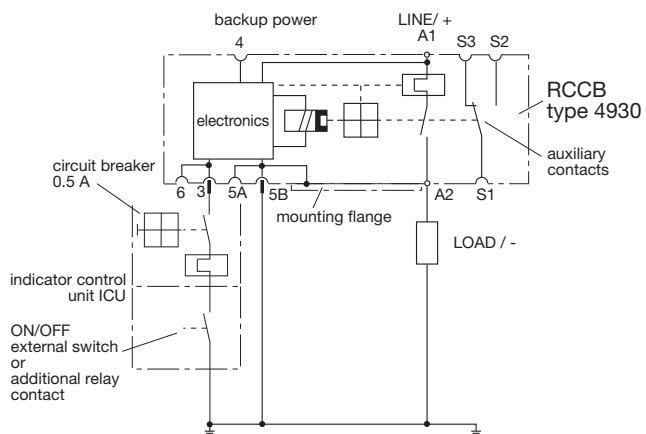

All dimensions without tolerances are for reference only. In the interest of improved design, performance and cost effectiveness the right to make changes in these specifications without notice is reserved. Product markings may not be exactly as the ordering codes. Errors and omissions excepted.