

Description

Single pole high performance thermal-magnetic circuit breaker with tease-free, trip-free, snap action mechanism and toggle actuation (S-type TM CBE to EN 60934). Options include auxiliary contacts, a moulded flame retardant enclosure for added environmental protection, and remote operation - disconnection only, or disconnection and re-connection. Now also available in an IP65 housing (see E-1032, page 269).

Typical applications

Battery and cable protection for all types of vehicles (including rail vehicles and boats), battery powered systems.

Ordering information

Type No.	437	single pole, toggle actuator (2-pole upon request)
Enclosure design (optional)	B3	moulded, high environmental protection degree, without operating knob
B31	moulded, high environmental protection degree, with operating knob	
B35	as B31, but for remote disconnection and re-connection facility	
C3	housing without operating knob, single pole, IP65	
Terminal design	K12	flat screw terminals M10, for enclosure B3, B31 or B35
K60	flat screw terminals DIN 46206, sheet 2, form 1, thread M10	
K71	compulsory and only for C3 housing	
Mounting	1	lugs
2	compulsory and only for C3 housing	
5	brackets	
Characteristic curve	06	fast trip
07	delayed trip	
Auxiliary contacts (blade terminals 6.3x08)	Si	one each N/O and N/C
Si01	one N/C (11/12), two N/O (13/14 + 23/24)	
Si2	one N/O (13/14)	
2Si2	two N/O	
Remote trip (optional)	FA	electrical remote disconnection
FC	electrical remote disconnection (FA) and re-connection (FE)	
BC-FA	electrical remote disconnection (FA) and manual/remote re-connection not for enclosure B and C	
Coil voltage	12	DC 12 V
24	DC 24 V	
	(higher voltage ratings upon request)	
Current ratings	40...240 A	
Voltage ratings	(blank) ≤ DC 110 V	
B	> DC 110 V	

437 - ... - K60 - 5 - 06 - 2Si2 - FA 24 - 50A - ... ordering example

The exact part number required can be built up from the table of choices shown above. Ordering references for optional features should be omitted if not required.

Standard current ratings and typical internal resistance values

Current rating (A)	Internal resistance (Ω)	Current rating (A)	Internal resistance (Ω)
40	< 0.003	120	≤ 0.002
50	< 0.002	160	≤ 0.001
63	≤ 0.002	200	≤ 0.001
80	≤ 0.002	240	≤ 0.001
100	≤ 0.002		



437-...

Technical data

Voltage rating	DC 144 V (higher voltage ratings upon request)	
Current rating range	40...240 A (higher current ratings upon request)	
Auxiliary contact rating	6 A max. at DC 28 V 0.2 A at DC 180 V	
Electrical remote disconnection (-FA)	operating voltage DC 12 V or DC 24 V operating current approx. 18 A or 12 A max. pulse time 10 ms < t _{ON} < 20 ms / t _{OFF} > 10 s switching time < 20 ms	
Electrical remote re-connection (-FC)	operating voltage DC 12 V or DC 24 V operating current approx. 30 A or 15 A max. pulse time 0.1 s < t _{ON} < 1.2 s / t _{OFF} > 60 s switching time < 100 ms	
Typical life	3,000 operations at 240 A, DC 180 V 10,000 operations at 240 A, DC 28 V 20,000 operations mechanical	
Ambient temperature	-40...+60 °C (-40...+140 °F)	
Insulation co-ordination (IEC 60664 and 60664 A)	rated impulse withstand voltage 6 kV	pollution degree 3
Dielectric strength (IEC 60664 and 60664 A)	test voltage operating area AC 3,300 V main to aux. circuit AC 2,200 V aux. circuits 11-12 to 13-14 AC 1,000 V	
Insulation resistance	> 100 MΩ (DC 500 V)	
Interrupting capacity I _{cn}	2,000 A at DC 180 V; L/R = 0 ms 10,000 A at DC 28 V; L/R = 0 ms 7,500 A at DC 28 V; L/R = 13 ms	
Degree of protection (IEC 60529/DIN 40050)	operating area IP40, terminal area IP00 with enclosure B IP54 with enclosure C IP65	
Vibration	curve 06: 3 g (60-500 Hz), ± 0.23 mm (10-60 Hz) curve 07: 4 g (60-500 Hz), ± 0.30 mm (10-60 Hz) to IEC 60068-2-6, test Fc, 10 frequency cycles/axis	
Shock	curve 06: 20 g (11 ms), to IEC 60068-2-27, test Ea curve 07: 25 g (11 ms), to IEC 60068-2-27, test Ea	
Corrosion	48 hours at 5 % salt mist, to IEC 60068-2-11, test Ka	
Humidity	240 hours at 95 % RH, to IEC 60068-2-3, test Ca	
Mass	approx. 900 g base unit + approx. 400 g remote disconnection + approx. 100 g remote re-connection + approx. 750 g B housing + approx. 1,000 g C housing	

Dimensions

Moulded enclosure IP54 -B3

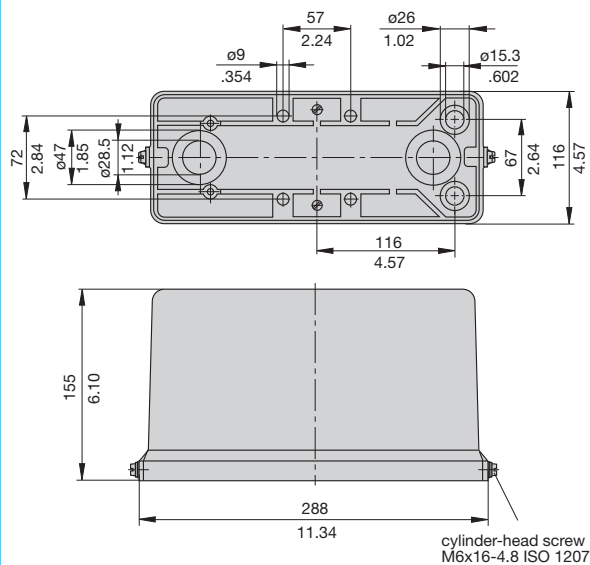

Moulded enclosure IP65 -C3

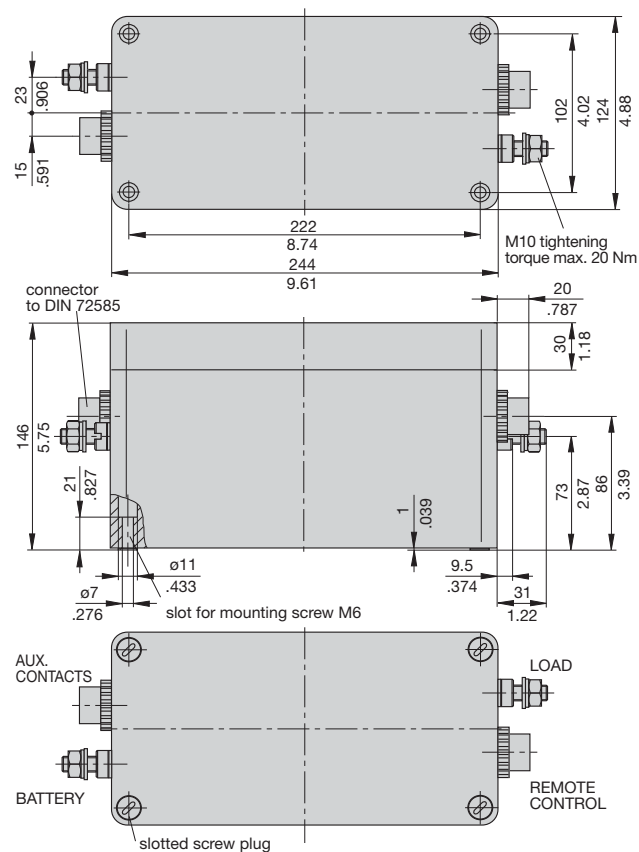

Dimensions

437-K12-5-Si-...-FA

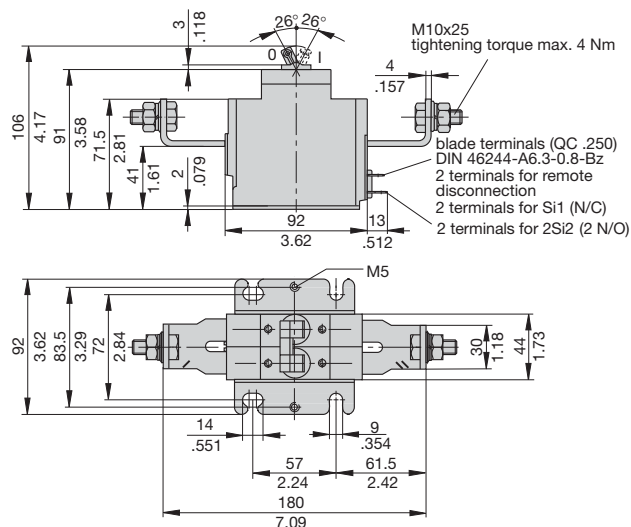

437-K60-1-...-FA

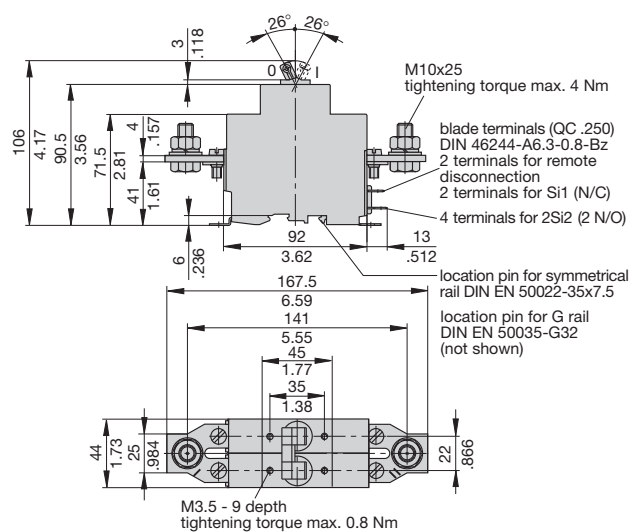

Terminals with housing C3

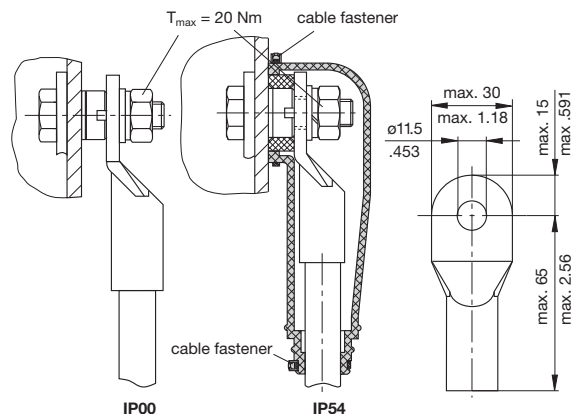

Rubber caps and cable fasteners are supplied with the product.

Dimensions

437-K12-...-BC-FA..

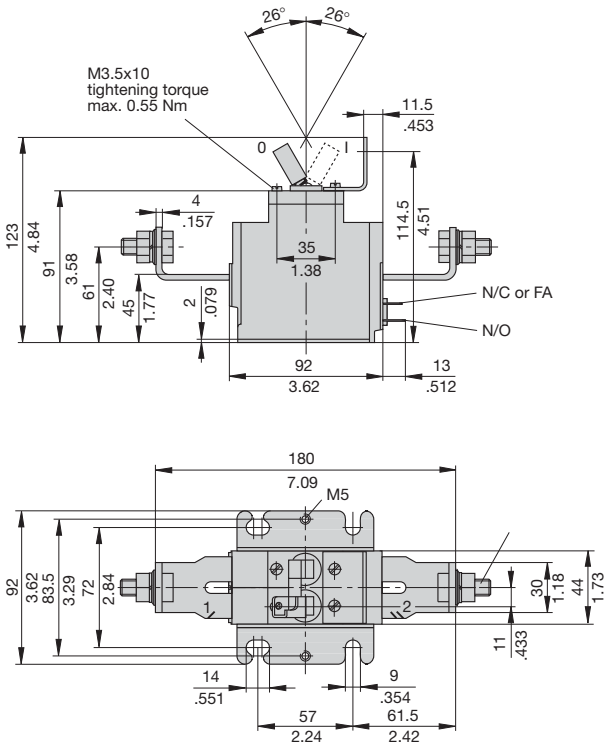

Internal connection diagram

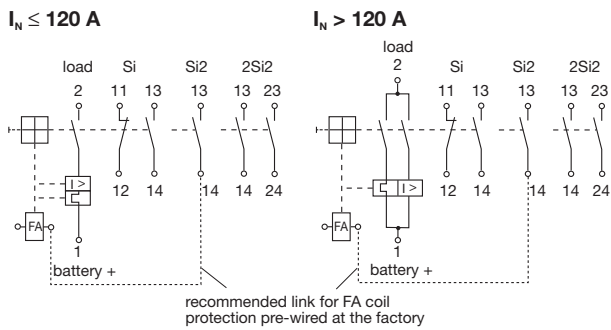

for housing C3

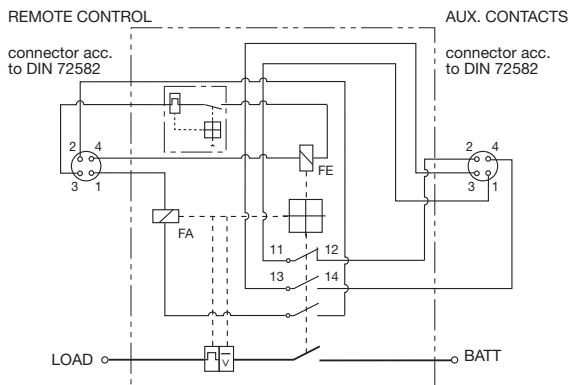

Typical time/current characteristics at +23 °C/+73.4 °F

Curve 06 (fast trip)

DC

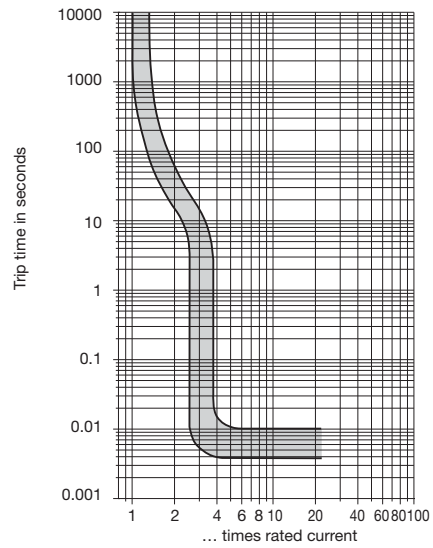

Curve 07 (delayed trip)

DC

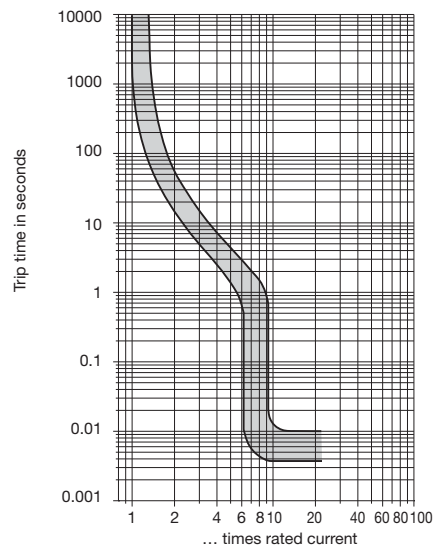

This is a metric design and millimeter dimensions take precedence ($\frac{mm}{inch}$)

All dimensions without tolerances are for reference only. In the interest of improved design, performance and cost effectiveness the right to make changes in these specifications without notice is reserved. Product markings may not be exactly as the ordering codes. Errors and omissions excepted.