

Description

Single pole high performance version of type 3200 (section 2) thermal-magnetic circuit breaker with tease-free, trip-free, snap action mechanism and additional manual release (M-type TM CBE to EN 60934). Designed for plug-in mounting with E-T-A sockets 10R or 16. Available with optional silver plated terminal pins for use in corrosive environments. Approved to CBE standard EN 60934 (IEC 60934).

Typical applications

Extra low voltage systems, control equipment.

Ordering information

Type No.

428	plug-in
	Current ratings
	0.05...25 A
428 - 10 A	ordering example

Standard current ratings and typical internal resistance values

Current rating (A)	Internal resistance (Ω)	Current rating (A)	Internal resistance (Ω)
0.05	534	4	0.1407
0.1	149	5	0.1068
0.2	56	6	0.0627
0.3	24.2	7	0.0491
0.4	13.65	8	≤ 0.02
0.5	8.08	10	≤ 0.02
0.6	5.25	12	≤ 0.02
0.8	3.55	14	≤ 0.02
1	2.02	15	≤ 0.02
1.5	0.904	16	≤ 0.02
2	0.514	18	≤ 0.02
2.5	0.36	20	≤ 0.02
3	0.23	25	≤ 0.02

Approvals

Authority	Voltage ratings	Current ratings
VDE (EN 60934)	AC 240 V; DC 28 V	0.05...25 A



428-...

Technical data

For further details please see chapter: **Technical Information**

Voltage rating	AC 250 V (50/60 Hz); DC 28 V	
Current rating range	0.05...25 A	
Typical life	2,000 operations at 1 x I _N , inductive 4,000 operations at 1 x I _N , resistive	
Ambient temperature	-30...+60 °C (-22...+140 °F)	
Insulation co-ordination (IEC 60664 and 60664A)	rated impulse withstand voltage 2.5 kV	pollution degree 2 reinforced insulation in operating area
Dielectric strength (IEC 60664 and 60664A) operating area	test voltage AC 3,000 V	
Insulation resistance	> 100 MΩ (DC 500 V)	
Interrupting capacity I _{cn}	0.05...5 A 400 A 5.5...7.5 A 750 A 8...25 A 1,500 A (with back-up fuse NH 40 A to IEC 60269/VDE 0636)	
Degree of protection (IEC 60529/DIN 40050)	operating area IP40 terminal area IP00	
Vibration	5 g (57-500 Hz), ± 0.38 mm (10-57 Hz) to IEC 60068-2-6, test Fc 10 frequency cycles/axis	
Shock	25 g (11 ms) to IEC 60068-2-27, test Ea	
Corrosion	96 hours at 5 % salt mist to IEC 60068-2-11, test Ka	
Humidity	240 hours at 95 % RH to IEC 60068-2-3, test Ca	
Mass	approx. 50 g	

Dimensions

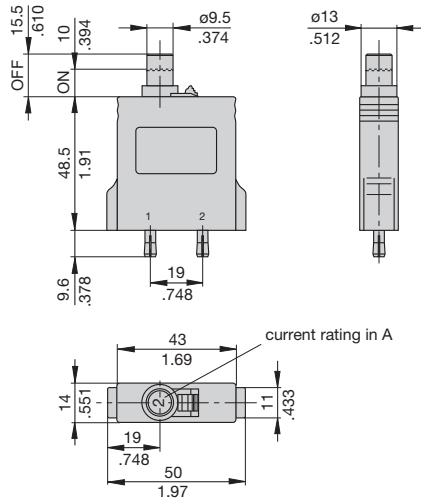

Installation drawing

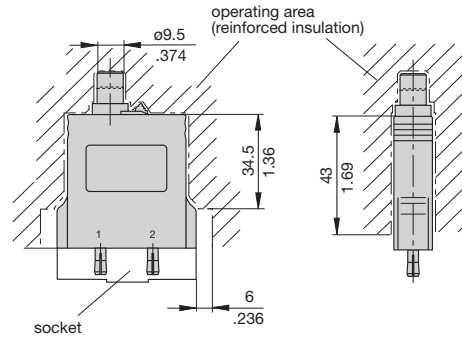

Internal connection diagram

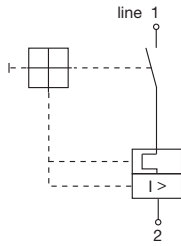

This is a metric design and millimeter dimensions take precedence ($\frac{\text{mm}}{\text{inch}}$)

Typical time/current characteristics

0.05 ... 7 A

AC/DC ¹⁾

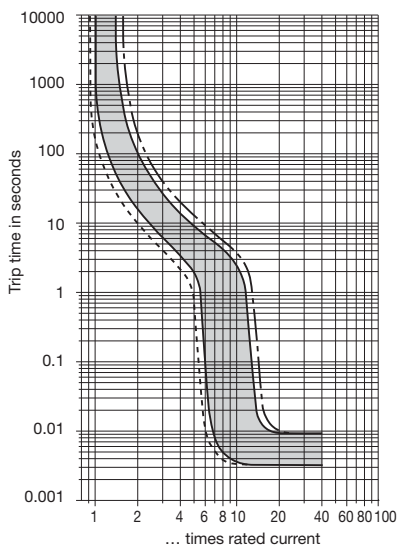

8 ... 16 A

AC/DC ¹⁾

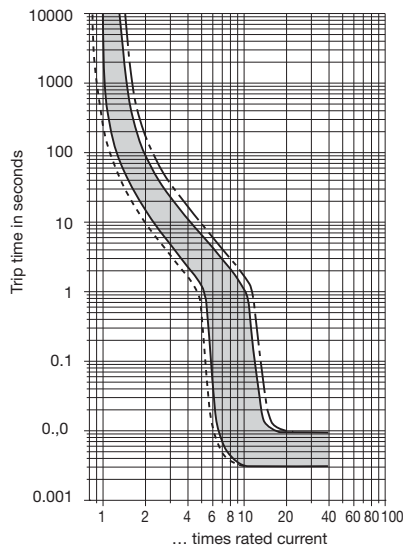

18 ... 25 A (for $I_N \geq 20$ A 50% ON duty/30 minutes)

AC/DC ¹⁾

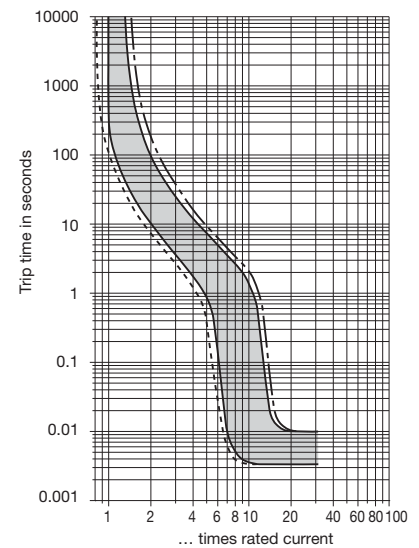

¹⁾ Magnetic tripping currents are increased by 20% on DC supplies.

Accessories

Sockets 10R-K10 (continuous load up to 20 A)

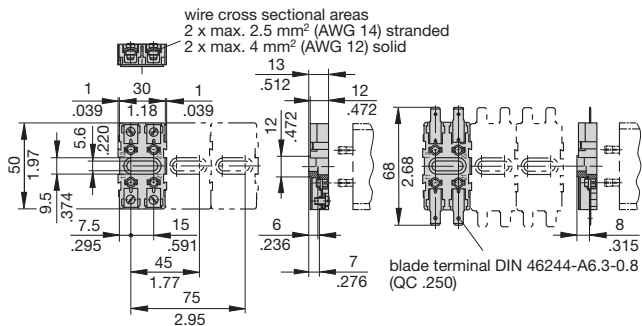

10R-P10 (continuous load up to 16 A)

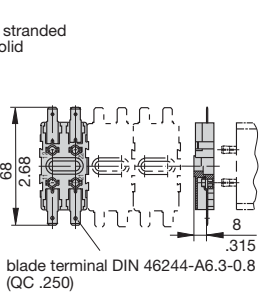

10R-A10 (continuous load up to 16 A)

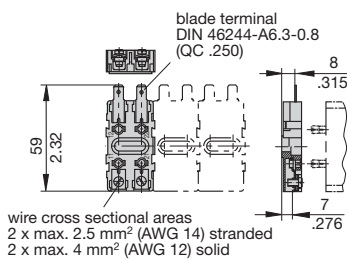

Bus bars for sockets 10-....: (continuous load up to 20 A)

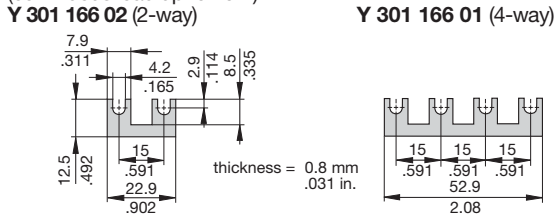

Socket 16 (continuous load up to 16 A)

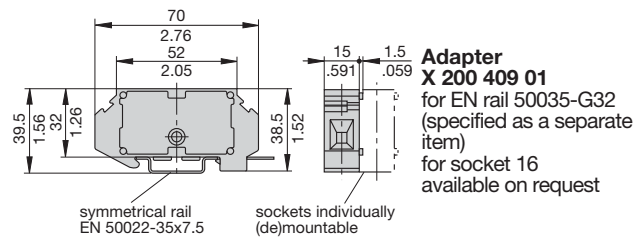

Blanking plug Y 301 477 01 for sockets 10R-P10/K10/A10

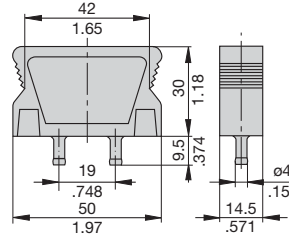

Terminal for mounting rack X 200 800 01 for socket 10R, 10F on EN rail 50 035-G32

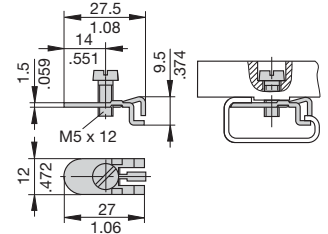

Connector bus links -K10 X 210 589 01/ 2.5 mm² (AWG 14), black (up to 20 A max. load) X 210 589 02/ 1.5 mm² (AWG 16), brown (up to 13 A max. load) for sockets 10R-P10, 10R-A10 and Nr. 16

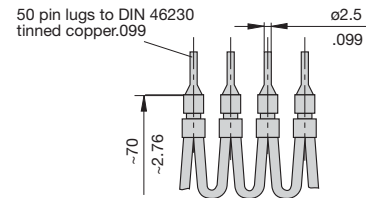

Connector bus links -P10 X 210 588 01/ 1.5 mm² (AWG 16), brown (up to 13 A max. load) X 210 588 02/ 2.5 mm² (AWG 14), black (up to 20 A max. load) X 210 588 03/ 2.5 mm² (AWG 14), red (up to 20 A max. load) X 210 588 04/ 2.5 mm² (AWG 14), blue (up to 20 A max. load)

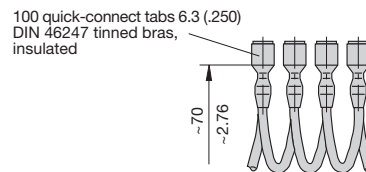

This is a metric design and millimeter dimensions take precedence ($\frac{\text{mm}}{\text{inch}}$)

All dimensions without tolerances are for reference only. In the interest of improved design, performance and cost effectiveness the right to make changes in these specifications without notice is reserved. Product markings may not be exactly as the ordering codes. Errors and omissions excepted.