

## Description

Single pole high performance thermal circuit breaker, with push-to-reset tease free, trip-free snap action mechanism (R-type TO CBE to EN 60934). Designed for threadneck panel mounting and for applications with a high fault current switching requirement. Approved to CBE standard EN 60934 (IEC 60934).

## Typical applications

Motors, transformers, solenoids, battery chargers, power supplies, appliances, machinery, extra low voltage systems.

## Ordering information

### Type No.

4130 single pole thermal circuit breaker

### Mounting

G threadneck panel mounting

### Threadneck design

2 M12x1, knurled nut (bulk shipped)

4 M12x1, hex nut and knurled nut (bulk shipped)

### Number of poles

1 single pole, thermally protected

### Actuator configuration

1 black push button

### Terminal design

K4 terminal M6x8

screw and washer bulk shipped

### Characteristic curve

M1 medium delay

### Current ratings

20... 70 A

4130 - G 2 1 1 - K4 M1 - 20 A ordering example

## Standard current ratings and typical internal resistance values

Current rating (A)	Internal resistance (Ω)	Current rating (A)	Internal resistance (Ω)
20	< 0.02	40	< 0.01
25	< 0.02	50	< 0.01
30	< 0.02	60	< 0.01
35	< 0.02	70	< 0.01

## Approvals

Authority	Voltage ratings	Current ratings
VDE (EN 60934)	AC 240 V; DC 50 V	20...70 A
UL	AC 240 V; AC 120 V; DC 50 V	20...80 A



4130-...

## Technical data

For further details please see chapter: Technical Information

Voltage rating	AC 240 V; DC 50 V		
Current rating range	20...70 A		
Typical life	AC 240 V: 20...70 A 100 operations at $2 \times I_N$ , inductive 500 operations at $2 \times I_N$ , resistive DC 50 V: 20...80 A 500 operations at $2 \times I_N$ , inductive		
Ambient temperature	-30...+60 °C (-22...+140 °F)		
Insulation co-ordination (IEC 60664)	rated impulse withstand voltage 2.5 kV (reinforced insulation in the mounting area)	pollution degree 2	
Dielectric strength operating area	test voltage AC 3,000 V		
Insulation resistance	> 100 MΩ (DC 500 V)		
Interrupting capacity $I_{cn}$	800 A		
Interrupting capacity (UL 1077)	$I_N$	$U_N$	
	20...70 A	AC 240 V	1,000 A
	20...60 A	AC 120 V	3,500 A
	70 A	AC 120 V	2,000 A
	20...50 A	DC 50 V	3,500 A
	60...70 A	DC 50 V	2,000 A
Degree of protection (IEC 60529/DIN 40050)	operating area IP40 terminal area IP00		
Vibration	8 g (57-500 Hz) ± 0.61 mm (10-57 Hz) to IEC 60068-2-6, test Fc 10 frequency cycles/axis		
Shock	25 g (11 ms) to IEC 60068-27, test Ea		
Corrosion	96 hours at 5 % salt mist, to IEC 60068-2-11, test Ka		
Humidity	240 hours at 95 % RH to IEC 60068-2-78, test Cab		
Mass	approx. 55 g		

## Dimensions

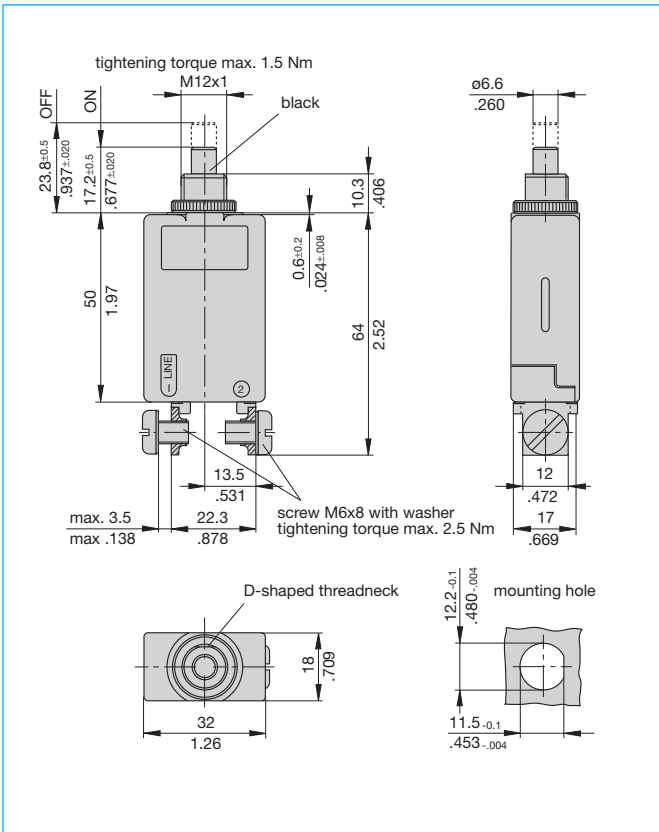

## Typical time/current characteristics

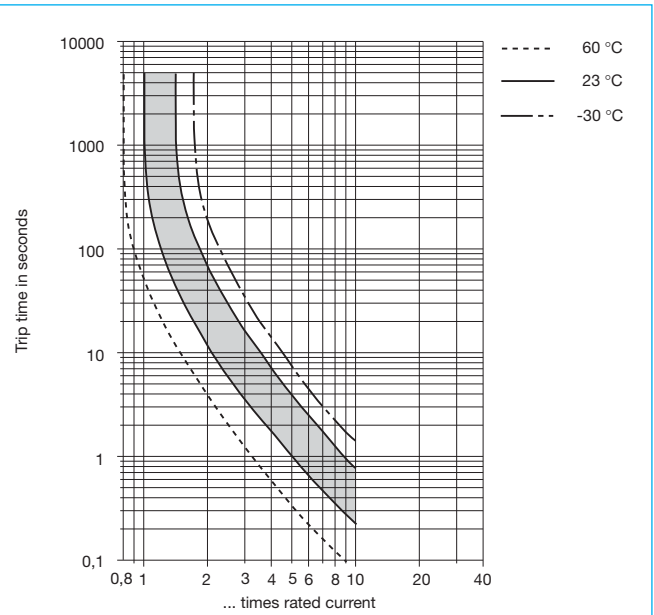

The time/current characteristic curve depends on the ambient temperature prevailing. In order to eliminate nuisance tripping, please multiply the circuit breaker current ratings by the derating factor shown below. See also section 9 – Technical information.

Ambient temperature °F	-22	-4	+14	+32	+73.4	+104	+122	+140
°C	-30	-20	-10	0	+23	+40	+50	+60
Derating factor	0.68	0.76	0.84	0.92	1	1.08	1.16	1.24

## Installation drawing

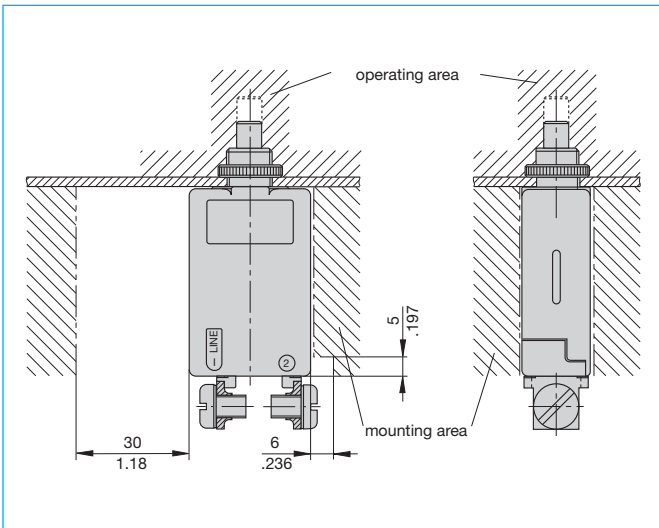

## Internal connection diagram

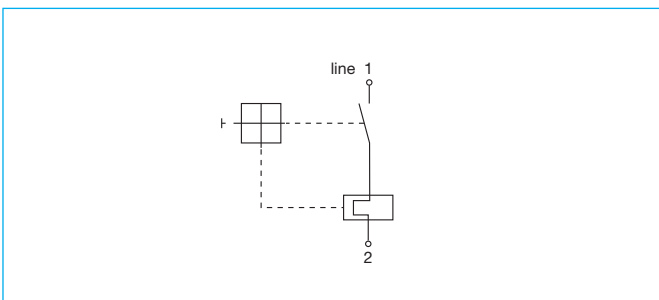

## Accessories

Hex nut with splash cover, black  
 X 201 296 01 without O ring (IP64)  
 X 200 801 03 with O ring (IP66 /IP67)  
 Hex nut with splash cover,  
 transparent  
 X 200 801 08 with O ring (IP66/IP67)

Water splash cover,  
 transparent with knurled  
 nut and O ring (IP64)  
 X 210 663 01

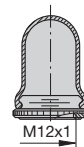

Separate hardware  
 Hex nut Y 300 116 02

Knurled nut  
 Y 302 065 01

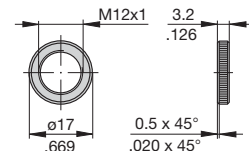
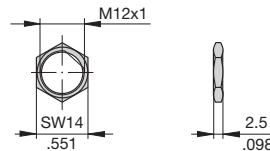

This is a metric design and millimeter dimensions take precedence  $\left(\frac{\text{mm}}{\text{inch}}\right)$

All dimensions without tolerances are for reference only. In the interest of improved design, performance and cost effectiveness the right to make changes in these specifications without notice is reserved. Product markings may not be exactly as the ordering codes. Errors and omissions excepted.