

## Description

Four pole switch or three pole switch/thermal circuit breaker (S-type TO CBE to EN 60934) with trip-free mechanism and red/green two button operation. Designed for snap-in panel mounting. Integral splash water protection to meet protection degree IP 66 in the operating area (option). Optional with under voltage release module and auxiliary contact module. Complies with CBE standard EN 60934 (IEC 60934).

## Typical applications

High-pressure cleaners, shredders, pumps, power saws, electric tools, motors, processing systems.

## Ordering information

### Type No.

**3140** four pole switch or three pole switch/circuit breaker

### Mounting

**F** snap in frame

### Frame

**1** standard

**2** splash water protected version

### Number of poles

**3** 3-pole, thermally protected

**7** 4-pole, thermally protected on 3 poles only

**C** 3-pole, unprotected, switch only

**D** 4-pole, unprotected, switch only

### Frame mounting

**0** panel thickness 1-6.35 mm (.04-.25 in)

### Terminal design

**P7** blade terminals 2x2.8x0.8 mm (QC 2x.110), DIN 46244-C

**N7** as P7, but with shunt terminal

**H7** as P7, but for terminals x.1 terminal screws M3.5 (required with X3140 fitted)

**G7** as H7, but with shunt terminal

### Characteristic curve

**T1** thermal

**Q1** switch only (10,000 operations)\*

### Switch style

**S** 2 push buttons (ON/OFF)

### Switch colour

**GRX** green/red

### Current rating range

**0.1...16 A**

**3140 - F 1 3 0 - P7 T1 - S GRX - 10 A** ordering example

\* only with terminal design N7 or G7

## Standard current ratings and typical internal resistance values

Current rating (A)	Internal resistance per pole (Ω)	Current rating (A)	Internal resistance per pole (Ω)
0.1	94	3.5	0.0595
0.2	24	4	0.0435
0.3	12	4.5	0.0325
0.4	5.30	5	0.0325
0.5	4.20	6	0.0215
0.6	2.90	7	0.0165
0.8	1.50	8	0.0125
1	0.9	10	< 0.02
1.2	0.80	12	< 0.02
1.5	0.45	14	< 0.02
2	0.27	15	< 0.02
2.5	0.0785	16	< 0.02
3	0.0595		



**3140**

## Technical data

For further details please see chapter: **Technical Information**

Voltage rating	3 AC 415 V; DC 50 V		
Current rating range	0.1...16 A		
Typical life	<b>3-pole</b>	10,000 operations at 1 x I <sub>N</sub> , inductive	
		10,000 operations at 1 x I <sub>N</sub> , resistive	
3 AC 415 V	<b>4-pole</b>	10,000 operations at 1 x I <sub>N</sub> , inductive	
		10,000 operations at 1 x I <sub>N</sub> , resistive	
Ambient temperature	-30...+60 °C (-22...+140 °F)		
Insulation co-ordination (IEC 60664 and 60664A)	rated impulse withstand voltage	pollution degree 2	
		reinforced insulation in operating area	
Dielectric strength (IEC 60664 and 60664A) operating area between poles (3-pole)	test voltage	AC 3,000 V	
		AC 1,500 V	
Insulation resistance	> 100 MΩ (DC 500 V)		
Interrupting capacity I <sub>cn</sub>	0.1...2 A	10 x I <sub>N</sub>	
	2.5...16 A	150 A	
Interrupting capacity (UL 1077)	I <sub>N</sub>	U <sub>N</sub>	3- and 4-pole
	0.1...16 A	AC 250 V	5,000 A
Degree of protection (IEC 60529/DIN 40050)	operating area IP40		
	(IP66 with water splash protection) terminal area IP00		
Vibration	5 g (57-500 Hz) ± 0.38 mm (10-57 Hz) to IEC 60068-2-6, test Fc, 10 frequency cycles/axis		
Shock	20 g (11 ms) to IEC 60068-2-27, test Ea		
Corrosion	96 hours at 5 % salt mist, to IEC 60068-2-11, test Ka		
Humidity	240 hours at 95 % RH, to IEC 60068-2-78, test Cab		
Mass	approx. 68		

## Approvals

Authority	Voltage ratings	Current ratings
VDE (EN 60934)	3 AC 415 V	0.1...16 A 3 + 4-pole
UL	AC 250 V	0.1...16 A 3 + 4-pole
CCC	3 AC 415 V	0.1...16 A 3 + 4-pole

All dimensions without tolerances are for reference only. In the interest of improved design, performance and cost effectiveness the right to make changes in these specifications without notice is reserved. Product markings may not be exactly as the ordering codes. Errors and omissions excepted.

## Dimensions

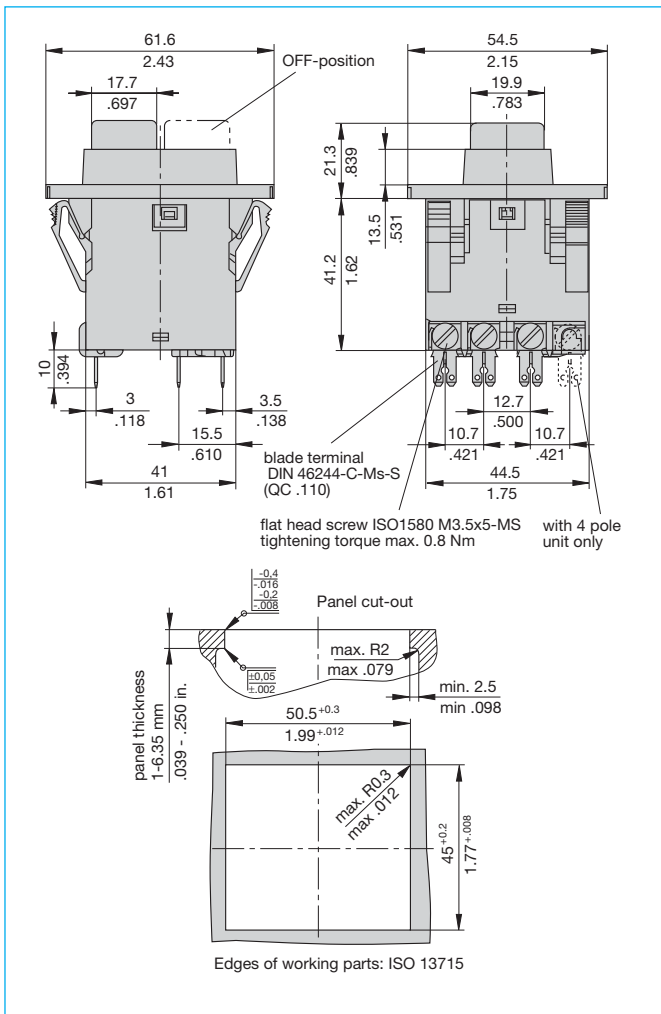

## Internal connection diagrams

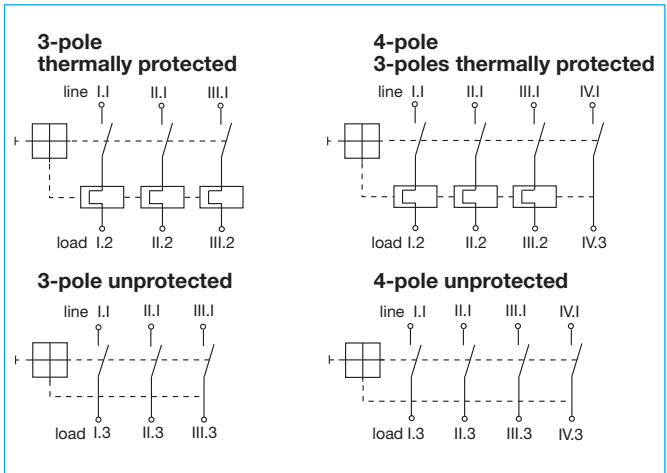

## Typical time/current characteristics

### 0.1 ... 2 A

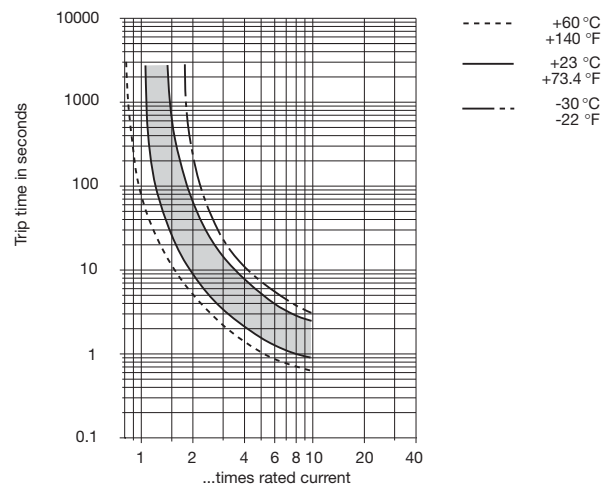

### 2.5 ... 16 A

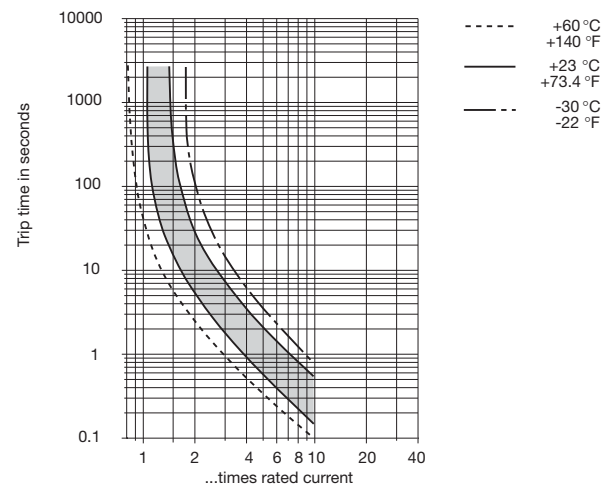

The time/current characteristic curve depends on the ambient temperature prevailing. In order to eliminate nuisance tripping, please multiply the circuit breaker current ratings by the derating factor shown below. See also section 9 – Technical information.

Ambient temperature °F	-22	-4	+14	+32	+73.4	+104	+122	+140
°C	-30	-20	-10	0	+23	+40	+50	+60
Derating factor	0.8	0.76	0.84	0.92	1	1.08	1.16	1.24

## Installation drawing

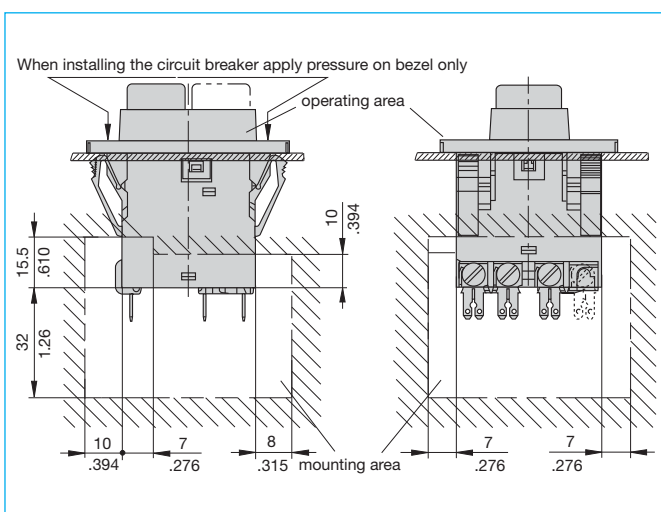

This is a metric design and millimeter dimensions take precedence (mm/inch)

## Description

A module suitable for all versions of type 3140 to trip the main switch/circuit breaker mechanism in the event of loss of voltage of the connected phases. When the voltage is restored the switch must be reset to reconnect the load, thereby avoiding the safety hazards associated with automatic re-starting of machinery.

**Note:** Basic unit 3140-... must be fitted with -H7 or -G7 screw terminals.

## Typical applications

Machines such as power tools, industrial equipment and domestic appliances where automatic restart after restoration of power could be dangerous (EU Machinery Directive).

## Ordering information

### Type No.

**X3140** Module for type 3140

### Function

**U** undervoltage release module

### Terminal design

- 00** standard (without separate connections)
- 01** one blade terminal 2.8x0.8 (QC .110)
- 02** two blade terminals 2.8x0.8 (QC .110)
- 03** as 01, with flying lead 0.5 mm<sup>2</sup> (l = 250 mm) and female connector 6.3x1 DIN 46247-MS

### Voltage ratings

- 00** AC 400 V 50/60 Hz
- 03** DC 24 V
- 09** AC 230 / 240 V 50/60 Hz

### Assembly status

- M** module mounted to the circuit breaker

**X3140 - U 00 00 M** ordering example

## Technical data

Voltage ratings	AC 400 V 50/60 Hz; AC 230 V; DC 24 V
Voltage tolerance	+10%/-15%
Current consumption	approx. 2.0 mA
Release values	$0.2 \times U_N < U < 0.7 \times U_N$ (at a rated voltage of AC 400 V the device may release at 280 V and must release at 80 V)
Release delay	$t < 20$ ms
Latch-in values	$\geq 85 \% U_N$
Ambient temperature	-30...+60 °C (-22...+140 °F)
Vibration	5 g (57-500 Hz) $\pm$ 0.38 mm (10-57 Hz) to IEC 60068-2-6, test Fc 10 frequency cycles/axis
Shock	20 g (11 ms) to IEC 60068-2-27, test Ea
Corrosion	48 hours at 5 % salt mist, to IEC 60068-2-11, test Ka
Humidity	240 hours at 95 % RH to IEC 60068-2-78, test Cab
Mass	approx. 90 g (complete assembly)

## Approvals (complete circuit breaker/module assembly)

Authority	Voltage ratings
VDE (EN 60934)	AC 400 V; AC 230/240 V; DC 24 V

## Dimensions

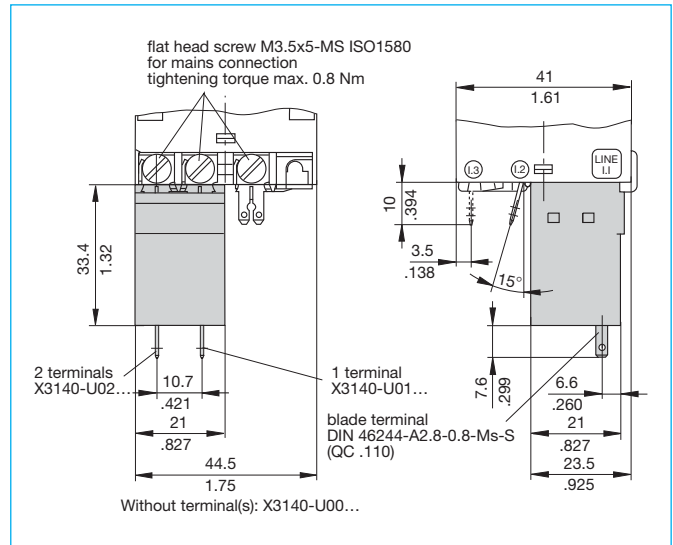

## Internal connection diagrams

### X3140-U00

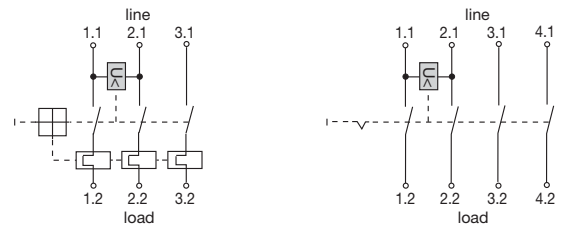

### X3140-U01

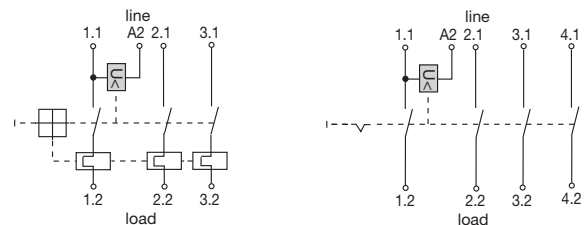

### X3140-U02

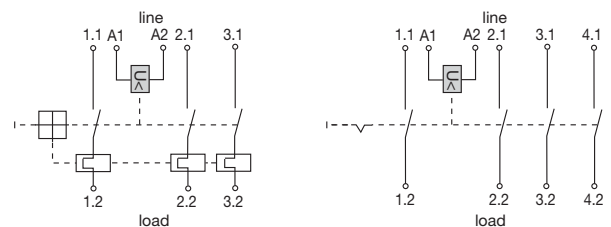

This is a metric design and millimeter dimensions take precedence ( $\frac{\text{mm}}{\text{inch}}$ )

All dimensions without tolerances are for reference only. In the interest of improved design, performance and cost effectiveness the right to make changes in these specifications without notice is reserved. Product markings may not be exactly as the ordering codes. Errors and omissions excepted.

## Description

A module supplied factory fitted to type 3140-F to provide electrically separate changeover contacts which operate as the main contacts open/close. Ideally suited to status signalling and sequence switching.

## Typical applications

Monitoring of the switching position of the circuit breaker or any connected load.

## Ordering information

<b>Type No.</b>			
<b>X3120</b>	Module for type 3120 and type 3140		
<b>Function</b>			
<b>S</b>	auxiliary contact module		
<b>Contact configuration</b>			
<b>0</b>	change-over contact		
<b>Terminal design</b>			
<b>1</b>	blade terminals 2.8 x 0.5 (QC .110), silver plated		
<b>Contact rating</b>			
AC		DC (not approved)	
Voltage rating	Current rating	Voltage rating	Current rating
<b>A</b> 10 V-250 V	0.1...4 A	12 V	0.1...4 A
		24 V	0.1...4 A
		60 V	0.1...1 A
		110 V	0.1...0,5 A
220 V	0.1...0,25 A		
<b>B</b> 5 V-250 V	0,05...1 A	5 V-250 V	0.05...1 A
<b>Assembly status</b>			
<b>M</b>	module mounted to circuit breaker 3140-...		
<b>X3120 - S 0 1 A M</b> ordering example			

## Technical data

Voltage rating	AC 250 V; DC 220 V
Current rating	0.1...4 A / 0.05...1 A
Typical life	50,000 operations
Ambient temperature	-30...+60 °C (-22...+140 °F)
Dielectric strength (IEC 60664 and 60664A) between main and auxiliary circuit	test voltage AC 3,000 V
Insulation resistance	> 100 MΩ (DC 500 V)
Vibration	6 g (type X3120-S...A) 8 g (type X3120-S...B) (57-500 Hz) ± 0.46 mm (10-57 Hz) to IEC 60068-2-6, test Fc 10 frequency cycles/axis
Shock	15 g (11 ms), type X3120-S...A 20 g (11 ms), type X3120-S...B to IEC 60068-2-27, test Ea
Corrosion	96 hours at 5 % salt mist, to IEC 60068-2-11, test Ka
Humidity	240 hours at 95 % RH to IEC 60068-2-78, test Cab
Mass	approx. 38 g (complete assembly)

## Approvals (complete circuit breaker/module assembly)

Authority	Voltage ratings	Current ratings
VDE (EN 60934)	AC 250 V; DC 28 V	0.05...4 A
UL, CSA	AC 250 V	0.05...4 A

## Dimensions

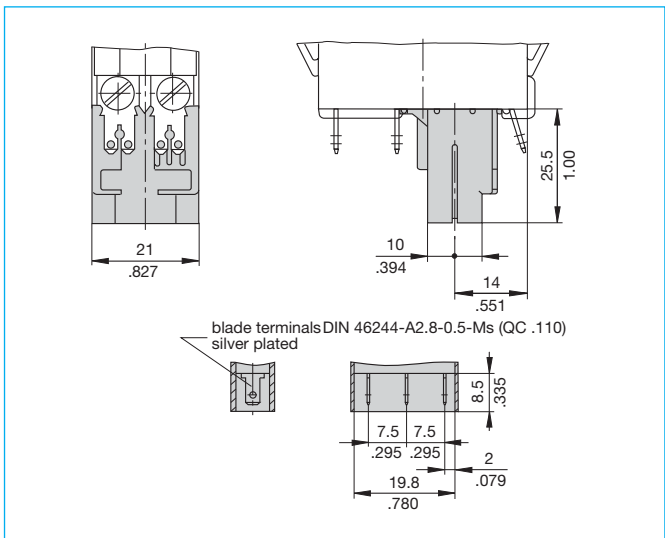

## Internal connection diagram

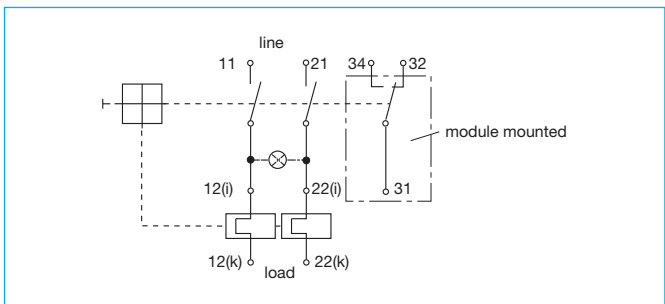

This is a metric design and millimeter dimensions take precedence ( $\frac{\text{mm}}{\text{inch}}$ )

All dimensions without tolerances are for reference only. In the interest of improved design, performance and cost effectiveness the right to make changes in these specifications without notice is reserved. Product markings may not be exactly as the ordering codes. Errors and omissions excepted.