

## Description

Single, two and three pole rocker switch/thermal trip free circuit breakers (S-type TO CBE to EN 60934) of compact design for snap-in panel mounting. Available either with protection on one/both/all poles or, in the case of the double pole version, protection on one pole only. Illumination is optional and there is a choice of rocker colours. Approved to CBE standard EN 60934 (IEC 60934).

## Typical applications

Motors, transformers, solenoids, household and office machines, electrical tools, mobile homes, boating, construction vehicles, medical equipment to EN 60601.

## Standard current ratings and typical internal resistance values

Current rating (A)	Internal resistance per pole ( $\Omega$ )	Current rating (A)	Internal resistance per pole ( $\Omega$ )
0.1	94	4	0.0435
0.2	24	5	0.0325
0.3	12	6	0.0215
0.4	5.30	7	0.0165
0.5	4.20	8	0.0165
0.8	1.50	10	< 0.02
1	0.9	12	< 0.02
1.2	0.80	14	< 0.02
1.5	0.45	15	< 0.02
2	0.27	16	< 0.02
2.5	0.0785	18	< 0.02
3	0.0595	20	< 0.02
3.5	0.0565		

## Illumination voltage/power consumption

operating voltage	power consumption	
	filament/neon (B)	LED (G, R, Y)
12 V	20 mA	9 mA
24 V	20 mA	9 mA
48 V	20 mA	1.5 mA
115 V	< 1.5 mA	< 1 mA*
230 V	< 1.5 mA	< 1 mA*
415 V	< 1 mA	not available

\* single pole version only

## Approvals

Authority	Voltage rating	Current rating
VDE (EN 60934)	AC 240/415 V	0.1...20 A single pole 0.1...16 A multipole
	DC 50 V	0.1...8 A single pole 0.1...16 A multipole
	DC 28 V	0.1...20 A single pole
	AC 250 V; DC 50 V 3 AC 250 V	0.1...16 A 1- and 2- pole 0.1...12 A 3-pole
UL, CSA	AC 250 V; DC 50 V 3 AC 250 V	0.1...16 A 1- and 2- pole 0.1...12 A 3-pole

All dimensions without tolerances are for reference only. In the interest of improved design, performance and cost effectiveness the right to make changes in these specifications without notice is reserved. Product markings may not be exactly as the ordering codes. Errors and omissions excepted.

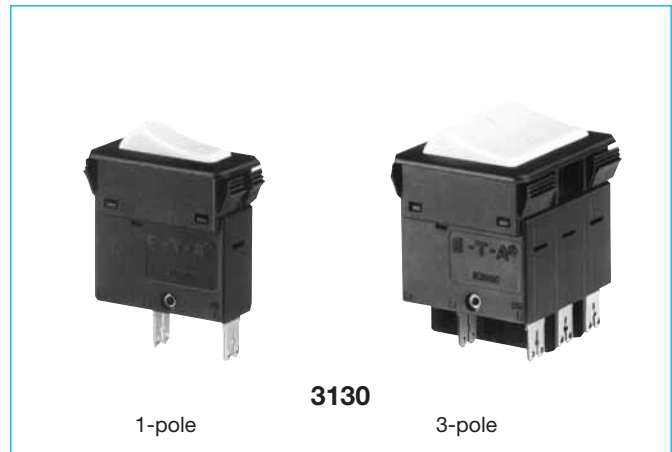

## Technical data

For further details please see chapter: Technical Information

Voltage rating	AC 240 V; 3 AC 415 V; DC 50 V (UL: AC 250 V; 3 AC 250 V; DC 50 V)		
Current ratings	0.1...20 A 1-pole 0.1...16 A 2- and 3-pole		
Typical life	<b>1-pole</b> AC 240 V: 0.1...20 A 30,000 operations at $1 \times I_N$ , inductive DC 50 V: 0.1...4 A 30,000 operations at $1 \times I_N$ , inductive 4.5...16 A 30,000 operations at $1 \times I_N$ , resistive DC 28 V: 4.5...20 A 30,000 operations at $1 \times I_N$ , inductive		
	<b>2-pole</b> AC 240 V: 0.1...16 A 50,000 operations at $1 \times I_N$ , inductive DC 50 V: 0.1...16 A 50,000 operations at $1 \times I_N$ , inductive		
	<b>3-pole</b> 3 AC 415 V: 0.1...16 A 30,000 operations at $1 \times I_N$ , inductive		
Ambient temperature	-30...+60 °C (-22...+140 °F)		
Insulation co-ordination (IEC 60664 and 60664 A)	rated impulse withstand voltage 2.5 kV reinforced insulation in operating area	pollution degree 2	
Dielectric strength (IEC 60664 and 60664A)	test voltage operating area current path/current path	AC 3,000 V AC 1,500 V	
Insulation resistance	> 100 M $\Omega$ (DC 500 V)		
Interrupting capacity $I_{cn}$	0.1...2 A 2.5...20 A 2.5...16 A 2.5...12 A 14 + 16 A	10 $\times I_N$ 150 A 250 A 150 A 130 A	1-pole 2-pole 3-pole 3-pole
Interrupting capacity (UL 1077)	$I_N$ 1- + 2-pole 3-pole 1- + 2-pole	0.1...12 A AC 250V/3500A 3AC 250V/5000A DC 50V/2000A	14...16 A AC 250V/3500A DC 50V/2000A
Degree of protection (IEC 60529/DIN 40050)	operating area IP40 terminal area IP00		
Vibration	5 g (57-500 Hz) $\pm$ 0.38 mm (10-57 Hz) to IEC 60068-2-6, test Fc 10 frequency cycles/axis		
Shock	1-pole: 25 g (11 ms) 2 + 3-pole: 20 g (11 ms) to IEC 60068-2-27, test Ea		
Corrosion	96 hours at 5 % salt mist, to IEC 60068-2-11, test Ka		
Humidity	240 hours at 95 % RH, to IEC 60068-2-78, test Cab		
Mass	approx. 45 g (three pole) approx. 31 g (double pole) approx. 17 g (single pole)		

## Ordering information - 1-pole

<b>Type No.</b>	3130	rocker switch/circuit breaker
<b>Mounting</b>	<b>F</b>	snap in frame
<b>Frame</b>	<b>1</b>	standard
	<b>3</b>	special single pole version
<b>Number of poles</b>	<b>1</b>	single pole, thermally protected
	<b>A</b>	1-pole, unprotected**
<b>Frame mounting</b>	<b>0</b>	panel thickness 1-2.5 mm (.039-.099 in) (only 3130-F1...)
	<b>1</b>	panel thickness 1.5-3.2 mm (.059-.126 in)(only 3130-F3.1...)
<b>Terminal design</b>	<b>P7</b>	blade terminals DIN 46244-C-Ms-S (QC 2x.110)
	<b>H7</b>	for terminals 1.1, 2.1 3.1 terminal screws M 3.5 for terminals 1.2, 2.2, 3.1 blade terminals (QC 2x.110)
	<b>N7</b>	blade terminals (QC 2x.110), with shunt terminal
<b>Characteristic curve</b>	<b>T1</b>	thermal, 1.05-1.4 I <sub>N</sub>
	<b>Q1</b>	switch, only with terminal design -N7
<b>Switch style</b>	<b>W</b>	rocker
	<b>U</b>	momentary switch function
<b>Switch colour designation</b>		opaque                      translucent
	<b>01</b>	black <b>12</b> white
	<b>02</b>	white <b>14</b> red
	<b>04</b>	red <b>19</b> green
	<b>09</b>	green <b>29</b> black, rocker with green dot
<b>Rocker markings</b>	<b>A</b>	dot (ON position, only with switch colour designation 29)
	<b>Q</b>	"I" and "O" moulded in
<b>Rocker illumination (optional)</b>	<b>12 Q Y</b>	white rocker, yellow LED, AC/DC
	<b>14 Q R</b>	red rocker, red LED, AC/DC
	<b>19 Q Y</b>	green rocker, yellow LED, AC/DC
	<b>29 A G</b>	black rocker with dot, green LED
<b>Illumination voltage range* (optional)</b>	<b>2</b>	10 - 14 V (G,R,Y)
	<b>3</b>	20 - 28 V (G,R,Y)
	<b>4</b>	42 - 54 V (R,Y)
	<b>6</b>	90 - 140 V (R,Y)
	<b>7</b>	185 - 275 V (R,Y)
	<b>X</b>	LED, DC 8 - 10 mA ***
<b>Current ratings</b>		<b>0.1...20 A</b>
<b>Ordering example</b>	3130 - F 1 1 0 - P7 T1 - W 12 Q Y 7 - 5 A	

\* N/A for non-illuminated version  
 \*\* unprotected poles have to ordered with terminal design N7  
 \*\*\* without series resistor and diode, to be selected by customer.  
 Recommendation:  
 10-14 V Rv 1.1 kΩ  
 20-28 V RV 2.7 kΩ  
 diode 1N4007

## Ordering information - multipole

<b>Type No.</b>	3130	rocker switch/circuit breaker multipole
<b>Mounting</b>	<b>F</b>	snap in frame
<b>Frame</b>	<b>1</b>	standard
<b>Number of poles</b>	<b>2</b>	2-pole, thermally protected
	<b>3</b>	3-pole, thermally protected
	<b>5</b>	2-pole, thermally protected on one pole only
	<b>6</b>	3-pole, thermally protected on two poles only
	<b>B</b>	2-pole, unprotected**
	<b>C</b>	3-pole, unprotected**
<b>Frame mounting</b>	<b>0</b>	panel thickness 1-2.5 mm (.039-.099 in) (only 3130-F1...)
<b>Terminal design</b>	<b>P7</b>	blade terminals DIN 46244-C-Ms-S (QC 2x.110)
	<b>H7</b>	for terminals 1.1, 2.1 3.1 terminal screws M 3.5; for terminals 1.2, 2.2, 3.1 blade terminals (QC 2x.110)
	<b>N7</b>	blade terminals DIN 46244-C-Ms-S (QC 2x.110), with shunt terminal
<b>Characteristic curve</b>	<b>T1</b>	thermal, 1.05-1.4 I <sub>N</sub>
	<b>Q1</b>	switch, only with terminal design -N7
<b>Switch style</b>	<b>W</b>	rocker
	<b>U</b>	momentary switch function
<b>Switch colour designation</b>		opaque                      translucent
	<b>01</b>	black <b>12</b> white
	<b>02</b>	white <b>14</b> red
	<b>04</b>	red <b>19</b> green
	<b>09</b>	green
<b>Rocker markings</b>	<b>Q</b>	"I" and "O" moulded in
<b>Rocker illumination (optional)</b>	<b>B</b>	filament (≤ AC/DC 48 V), neon (≥ AC 115 V)
	<b>G</b>	green LED, DC
	<b>R</b>	red LED, DC
	<b>Y</b>	yellow LED, DC
<b>Illumination voltage range* (optional)</b>	<b>2</b>	10 - 14 V (B,G,R,Y)
	<b>3</b>	20 - 28 V (B,G,R,Y)
	<b>4</b>	42 - 54 V (B,R,Y)
	<b>6</b>	90 - 140 V (B)
	<b>7</b>	185 - 275 V (B)
	<b>8</b>	320 - 450 V (B)
<b>Current ratings</b>		<b>0.1...16 A</b>
<b>Ordering example</b>	3130 - F 1 3 0 - P7 T1 - W 12 Q B 7 - 5 A	

\* N/A for non-illuminated version  
 \*\* unprotected poles have to ordered with terminal design N7

## Dimensions

### 3130-F110-...

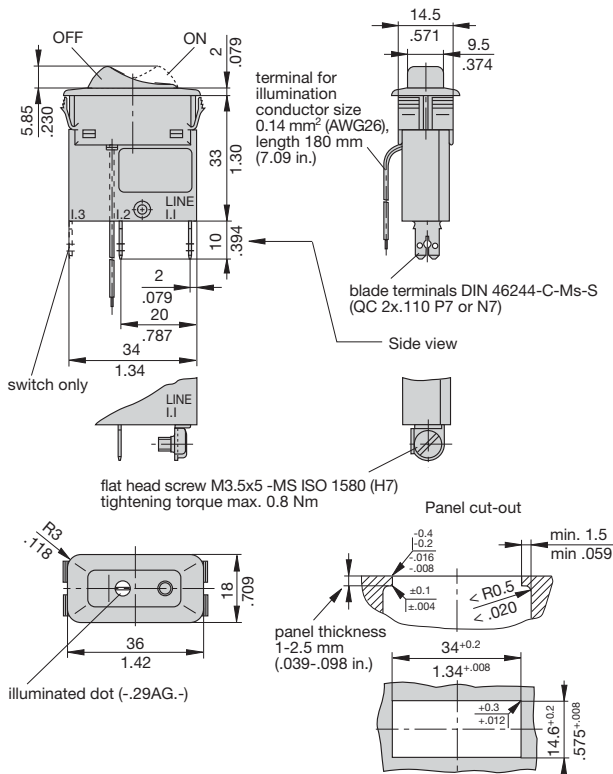

### 3130-F120-...

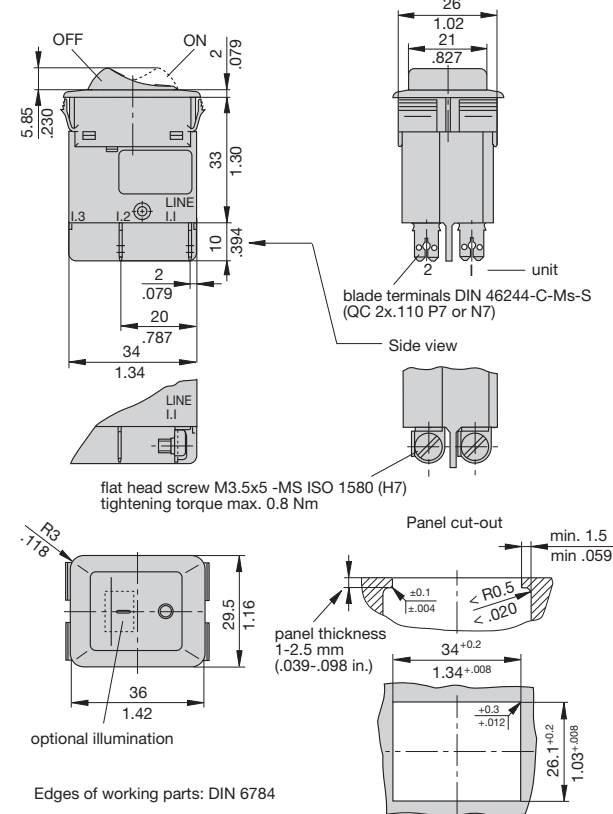

### 3130-F130-...

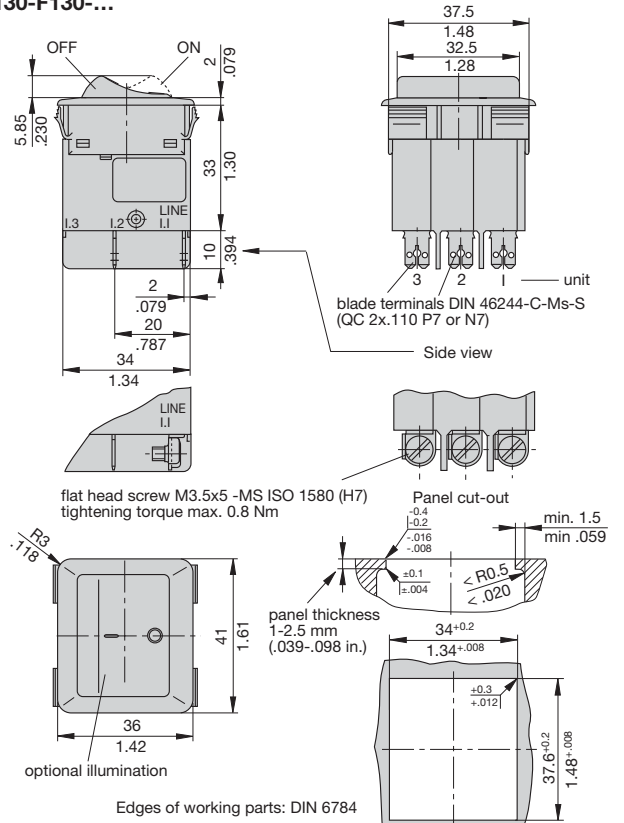

### 3130-F311-...

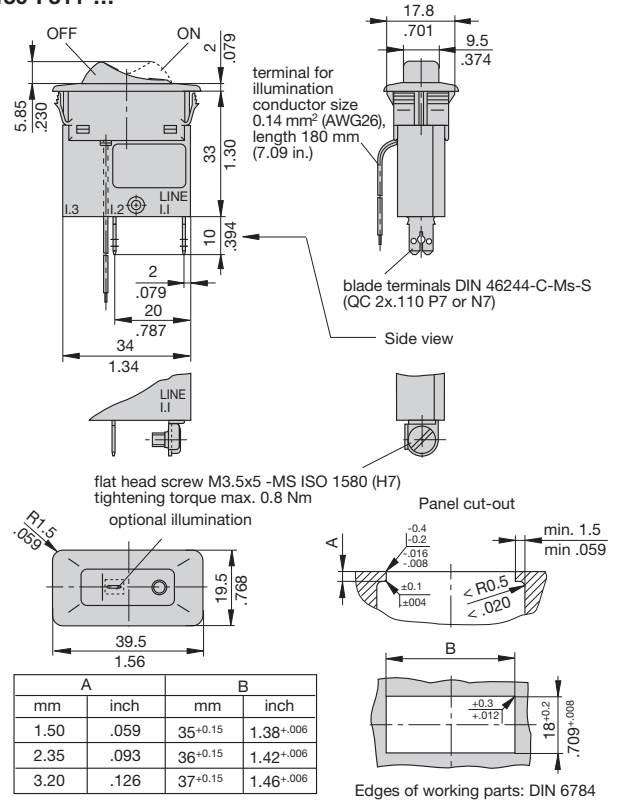

This is a metric design and millimeter dimensions take precedence (mm/inch)

## Installation drawing 3130-F1...

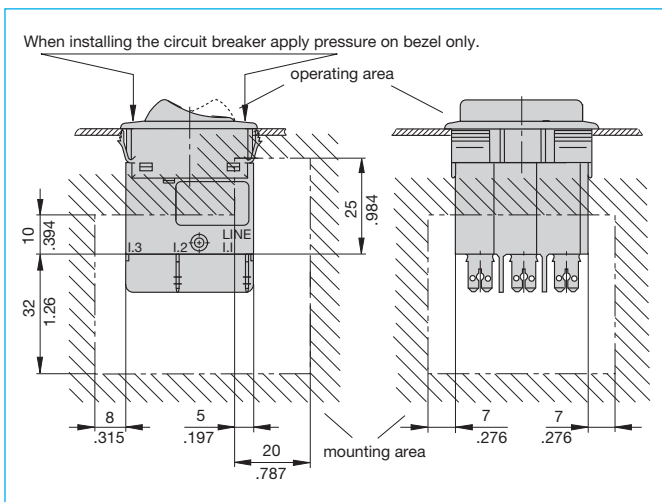

## Typical time/current characteristics

Multipole types: all poles symmetrically loaded.  
 With single pole overload, thermal tripping will be at approx.  $1.54 \times I_N$  with 2-pole devices and at approx.  $1.68 \times I_N$  with 3-pole devices.

### 0.1...2 A

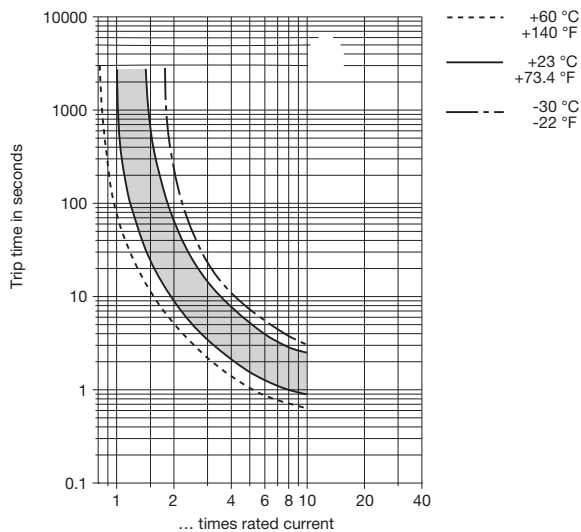

### 2.5...20 A 1-pole 2.5...16 A 2- and 3-pole

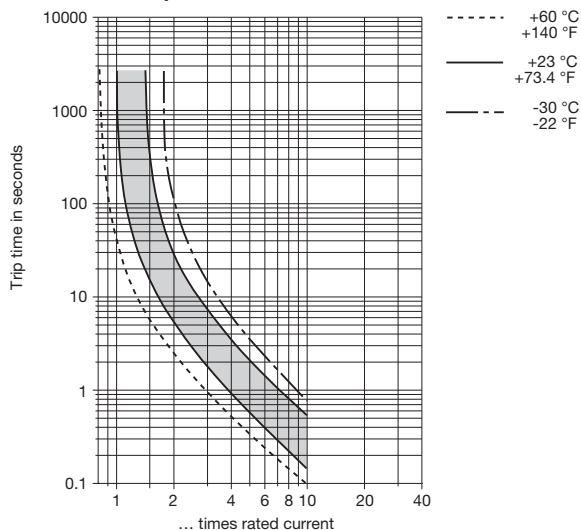

## Internal connection diagrams

### 1-pole

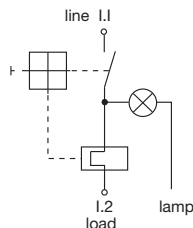

### 1-pole switch

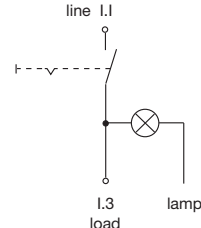

### 2-pole

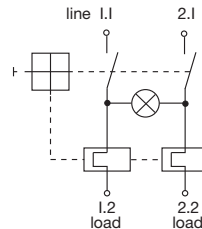

### 1-pole momentary switch

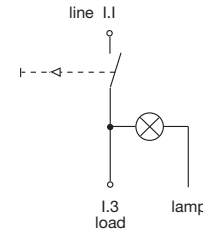

### 3-pole

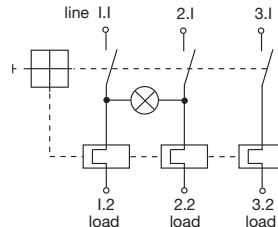

### 2-pole momentary switch

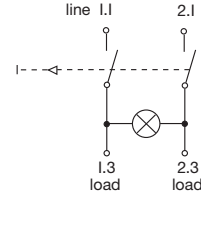

## Accessories 3130-F130-...

**Splash cover, transparent, for 3-pole version**  
**X 221 258 01** (IP54), comprising bezel Y 306 109 01  
 and transparent cover Y 306 108 01

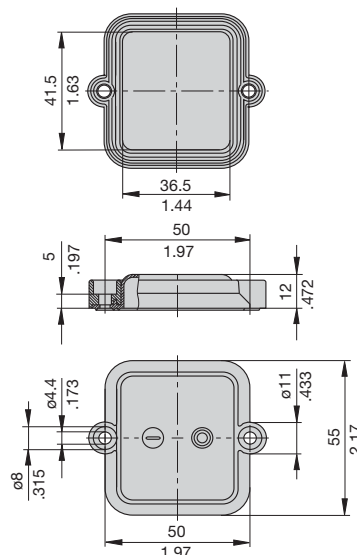

This is a metric design and millimeter dimensions take precedence ( $\frac{\text{mm}}{\text{inch}}$ )

The time/current characteristic curve depends on the ambient temperature prevailing. In order to eliminate nuisance tripping, please multiply the circuit breaker current ratings by the derating factor shown below. See also section Technical information.

Ambient temperature °F	-22	-4	+14	+32	+73.4	+104	+122	+140
°C	-30	-20	-10	0	+23	+40	+50	+60
Derating factor	0.8	0.76	0.84	0.92	1	1.08	1.16	1.24