

Description

Single pole thermal circuit breaker with push-to-reset, tease-free, trip-free, snap action mechanism (R-type TO CBE to EN 60934; M-type when fitted with optional manual release feature). Designed for plug-in mounting with E-T-A sockets 10 and 16.

Typical applications

Extra low voltage wiring systems and components.

Ordering information

Type No.	
2-5200	plug-in
	Manual release (optional)
H	manual release facility
	Current ratings
	0.05...16 A
2-5200 - H - .. - 5 A ordering example	

The exact part number required can be built up from the table of choices shown above. Ordering references for optional features should be omitted if not required.

Standard current ratings and typical internal resistance values

Current rating (A)	Internal resistance (Ω)	Current rating (A)	Internal resistance (Ω)
0.05	280	2.5	0.2
0.08	100	3	0.1
0.1	110	3,5	0.065
0.2	29	4	0.065
0.3	14	4.5	0.05
0.4	7	5	0.05
0.5	4.9	6	0.02
0.6	3.4	7	0.02
0.7	2.5	8	< 0.02
0.8	1.8	10	< 0.02
1	1.2	12	< 0.02
1.2	0.84	13	< 0.02
1.5	0.6	15	< 0.02
1.8	0.4	16	< 0.02
2	0.25		

Approvals

Authority	Voltage ratings	Current ratings
CSA/UL	AC 250 V	0.05...20 A
	DC 50 V	0.05...25 A



2-5200-...

Technical data

For further details please see chapter: Technical Information

Voltage rating	DC 28 V (UL: AC 250; DC 50 V)	
Current rating range	0.05...16 A (up to 25 A to special order)	
Typical life	AC 250 V / DC 28 V: 0.05...16 A 5,000 operations at 2 x I _N , inductive	
Ambient temperature	-20...+60 °C (-4...+140 °F)	
Insulation co-ordination (IEC 60664 and 60664 A)	rated impulse withstand voltage 2.5 kV	pollution degree 2
Dielectric strength (IEC 60664 and 60664A) operating area	test voltage AC 1,500 V	
Insulation resistance	> 100 MΩ (DC 500 V)	
Interrupting capacity I _{cn}	0.05...2.5 A 3...5 A 6...16 A	8 x I _N 20 x I _N 400 A
Interrupting capacity (UL 1077)	U _N AC 250 V DC 50 V	2,000 A 2,500 A
Degree of protection (IEC 60529/DIN 40050)	operating area IP40 terminal area IP00	
Vibration	8 g (57 to 500 Hz) ± 0.61 mm, (10-57 Hz), to IEC 60068-2-6, test Fc,	
Shock	25 g (11 ms) to IEC 60068-2-27, test Ea	
Corrosion	96 hours at 5 % salt mist, to IEC 60068-2-11, test Ka	
Humidity	240 hours at 95 % RH to IEC 60068-2-78, test Cab	
Mass	approx. 35 g	

All dimensions without tolerances are for reference only. In the interest of improved design, performance and cost effectiveness the right to make changes in these specifications without notice is reserved. Product markings may not be exactly as the ordering codes. Errors and omissions excepted.

Dimensions

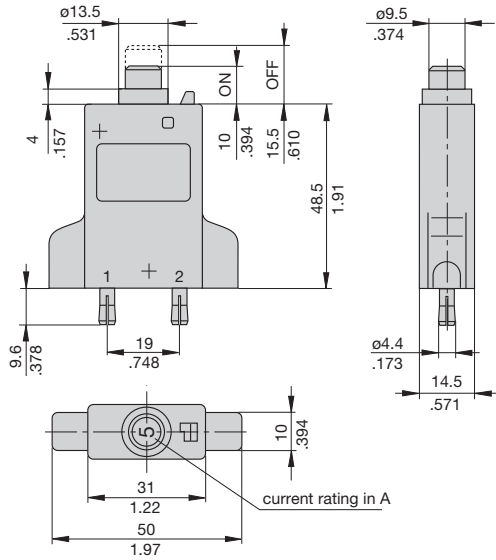

Internal connection diagram

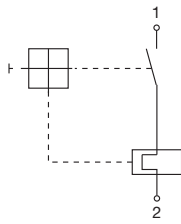

Typical time/current characteristics at +23 °C/+73.4 °F

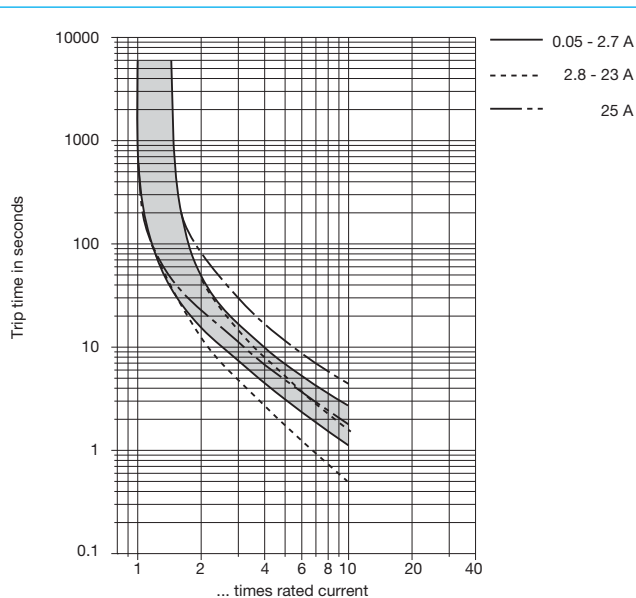

The time/current characteristic curve depends on the ambient temperature prevailing. In order to eliminate nuisance tripping, please multiply the circuit breaker current ratings by the derating factor shown below. See also section 9 – Technical information.

Ambient temperature °F	-4	+14	+32	+73.4	+104	+122	+140
°C	-20	-10	0	+23	+40	+50	+60
Derating factor	0.76	0.84	0.92	1	1.08	1.16	1.24

Accessories

Sockets 10R-K10

wire cross sectional areas
 2 x max. 2.5 mm² AWG 14 stranded
 2 x max. 4 mm² AWG 12 solid

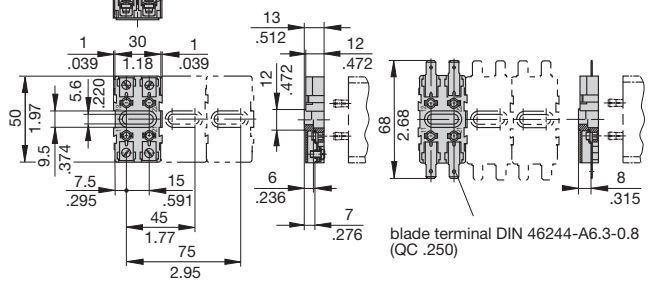

10R-P10

blade terminal DIN 46244-A6.3-0.8 (QC .250)

10R-A10

blade terminal DIN 46244-A6.3-0.8 (QC .250)

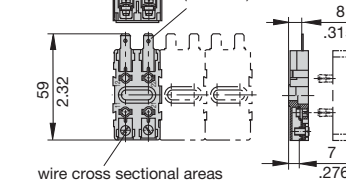

wire cross sectional areas
 2 x max. 2.5 mm² AWG 14 stranded
 2 x max. 4 mm² AWG 12 solid

Bus bar for sockets 10... Y 301 166 02 (2 way)

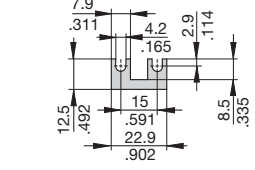

Y 301 166 01 (4 way)

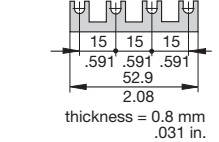

Socket 16

(up to 16 A max. load)

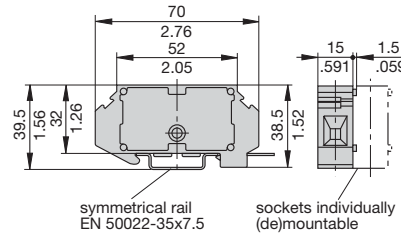

thickness = 0.8 mm
 .031 in.

Adapter for EN rail 50035-G32 (specified as a separate item)
X 200 409 01
 for socket 16 available on request

Blanking plug

Y 301 477 01
 for sockets 10R-P10/K10

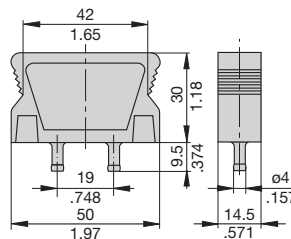

Terminal for mounting rack

X 200 800 01
 for sockets 10R, 10F on EN rail 50 035-G32

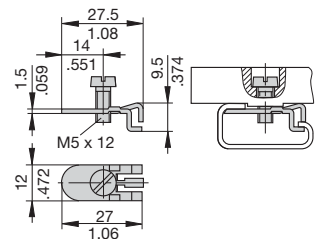

Connector bus links -P10

X 210 588 01/
 1.5 mm² (AWG 16) (brown)
X 210 588 02/
 2.5 mm² (AWG 14) (black)
X 210 588 03/
 2.5 mm² (AWG 14) (red)
X 210 588 04/
 2.5 mm² (AWG 14) (blue)

Connector bus links -K10

X 210 589 01/
 2.5 mm² (AWG 14) (black)
X 210 589 02/
 1.5 mm² (AWG 16) (brown)

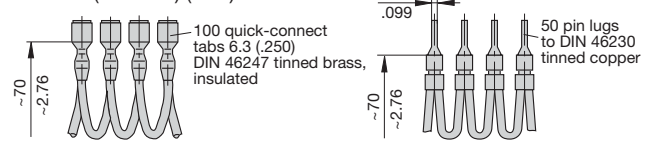

1.5 mm² - up to 13 A max. load
 2.5 mm² - up to 20 A max. load

This is a metric design and millimeter dimensions take precedence (mm/inch)