

Description

Single pole, thermal miniaturised circuit breaker designed for automotive applications. Fits into fuse blocks designed to ISO 8820-3, Type F.

Automatic reset (for DC 12 V only) and open circuit (modified reset to SAE) version optional. Open circuit version ensures contacts staying open as long as power is on. The circuit breaker will reset after the load is removed. Particularly suitable for installation in inaccessible locations.

Current ratings correspond to those of blade fuses. Clear colour coding of the ratings: blade fuse and circuit breaker of the same colour have the same rating.

Meets the requirements of SAE J553.

Typical applications

Protection of electrical systems of passenger cars, trucks, buses, watercraft, extra low voltage wiring systems.

Ordering information

Type No.	
1620	single pole thermal Mini-CBE with standard characteristic curve
Version, according to SAE J553	
1	type 1, DC 12 V automatic reset
2	type 2, modified reset (not yet available)
3	type 3, DC 24 V with reset button
3H	type 3*, DC 24 V with reset button and manual release facility
Voltage rating	
...	standard
1	12 V – only for type 2
2	24 V – only for type 2
Current ratings	
5	7.5 10 15 20 25 30 A
1620 - 1	- ... - 10 A ordering example

Current ratings, typical voltage drop values and colour coding

Current rating (A)	Voltage drop (mV)	Housing cap colour
5	< 150	light brown
7.5	< 150	brown
10	< 150	red
15	< 150	blue
20	< 150	yellow
25	< 150	white
30	< 150	light green

NEW



1620-1



1620-3



1620-3H

Technical data

Voltage rating	1620-1, 1620-2-1: DC 12 V 1620-2-2, 1620-3, 1620-3H: DC 12 V, DC 24 V
Max. voltage rating	1620-1, 1620-2-1: DC 14.5 V 1620-2-2, 1620-3, 1620-3H: DC 29.0 V
Current ratings	DC 12 V: 5...30 A DC 24 V: 5...25 A
Service short-circuit breaking capacity	300 operations at $2 \times I_N$
Ambient temperature	-40...85 °C (-40...+185 °F)
Reset period for 1626-1 (at 23 °C)	≤ 15 s
Reset period for 1626-2 (at 23 °C)	after 5 sec at rated voltage < 35 s
Degree of protection (IEC 60529)	operating area IP40 (-3) operating area IP50 (-1, -2) terminal area IP00
Ultimate short-circuit breaking capacity	≥ 3 break operations at 150 A, or ≥ 1 break operation at 2,000 A
Vibration	10 g (57-500 Hz), ± 0.38 mm (10-57 Hz) to IEC 60068-2-6, test Fc 10 frequency cycles/axis SAE-J553, Step No. 14, § 4.2.7.1.5
Shock	50 g (11 ms) to IEC 60068-2-27, test Ea SAE-J553, Step No. 14, § 4.2.7.1.6
Corrosion	24 hrs in 5 % salt mist, to IEC 60068-2-11, test Ka SAE-J553, Step No. 14, § 4.2.7.1.3
Humidity	240 hrs in 95 % RH, to IEC 60068-2-78, test Cab SAE-J553, Step No. 14, § 4.2.7.1.2
Mass	approx. 3 g

It is good practice to switch off the vehicle's ignition system before manually releasing or re-setting the circuit breaker. Free travel of the actuator must be ensured.

Depending on the socket used and with the 30 A device carrying a full load, the temperatures at the terminals may rise above the allowed SAE value.

Dimensions

1620-1 / 1620-2

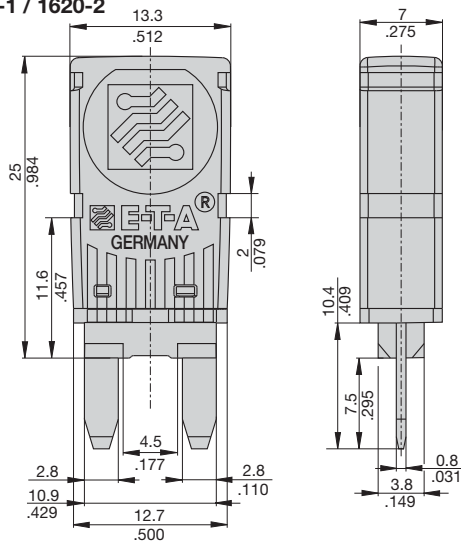

1620-3

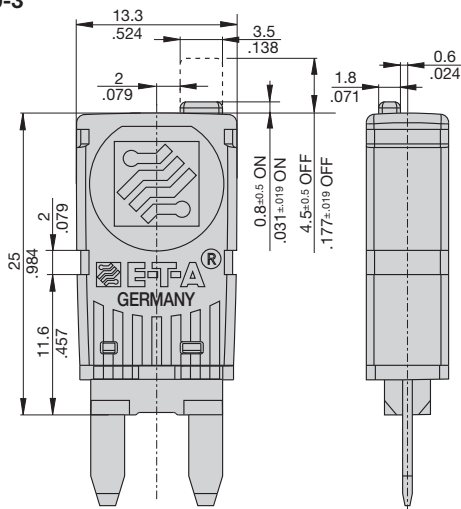

1620-3H

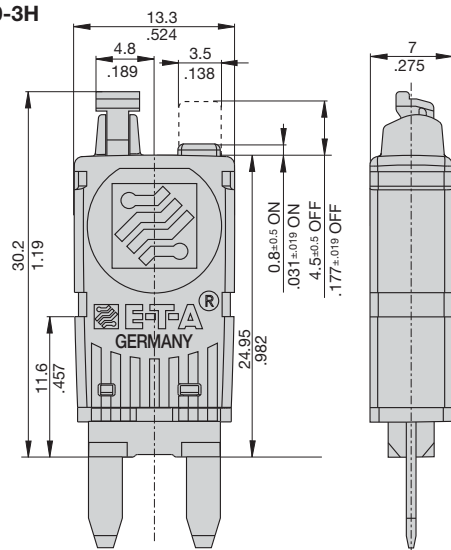

Internal connection diagrams

1620-1

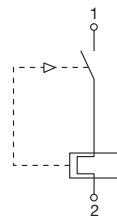

1620-2

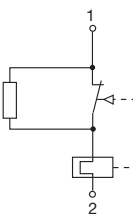

1620-3

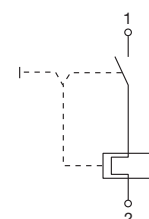

1620-3H

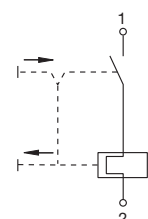

Typical time/current characteristic curve at +23 °C / +73.4 °F

5...30 A

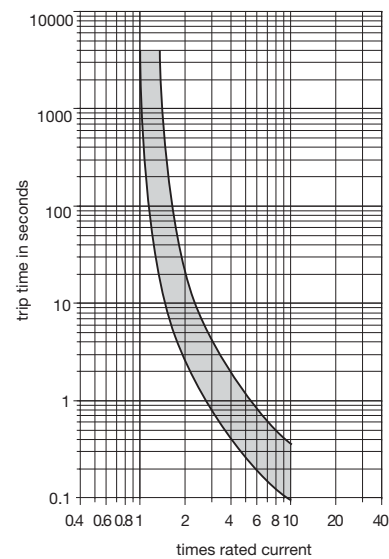

The time/current characteristic curve depends on the ambient temperature prevailing. In order to eliminate nuisance tripping, please multiply the circuit breaker current ratings by the derating factor shown below. See also section 9 – Technical information.

Ambient temperature	°F	-40	-22	-4	+14	+32	+50
	°C	-40	-30	-20	-10	0	10
Derating factor		0.73	0.78	0.82	0.86	0.91	0.95
Ambient temperature	°F	+73.4	+104	+122	+140	+158	+185
	°C	23	40	50	60	70	85
Derating factor		1	1.09	1.16	1.25	1.33	1.43

All dimensions without tolerances are for reference only. In the interest of improved design, performance and cost effectiveness the right to make changes in these specifications without notice is reserved. Product markings may not be exactly as the ordering codes. Errors and omissions excepted.