

Description

Single pole thermal circuit breaker with push-to-reset, tease-free, trip-free, snap action mechanism (R-type TO CBE to EN 60934). Available in versions for threadneck panel mounting, plug-in or integral mounting. The optional -KF housing is particularly suited to high humidity and other damp conditions. Approved to CBE standard EN 60934 (IEC 60934).

Typical applications

Motors, transformers, solenoids, extra low voltage wiring systems.

Ordering information

Type No.

157 threadneck panel mounting*

158 integral or plug-in mounting

Terminal design

P10 blade terminals A6.3-0.8 (QC .250)

K10 screw terminals M4x6

Special housing (optional)

KF for tropical and high humidity conditions

Current ratings

0.05...25 A

157 - P10 - .. - 10 A = ordering example

The exact part number required can be built up from the table of choices shown above. Ordering references for optional features should be omitted if not required.

*mounting hardware bulk shipped

Standard current ratings and typical internal resistance values

Current rating (A)	Internal resistance (Ω)	Current rating (A)	Internal resistance (Ω)
0.05	280	3	0.1
0.08	100	3.5	0.06
0.1	110	4	0.06
0.2	29	4.5	0.05
0.3	14	5	0.05
0.4	7	6	0.02
0.5	4.9	7	0.02
0.6	3.4	8	0.02
0.7	2.5	10	< 0.02
0.8	1.8	12	< 0.02
1	1.2	13	< 0.02
1.2	0.8	15	< 0.02
1.5	0.6	16	< 0.02
1.8	0.2	20	< 0.02
2	0.3	22	< 0.02
2.5	0.2	25	< 0.02

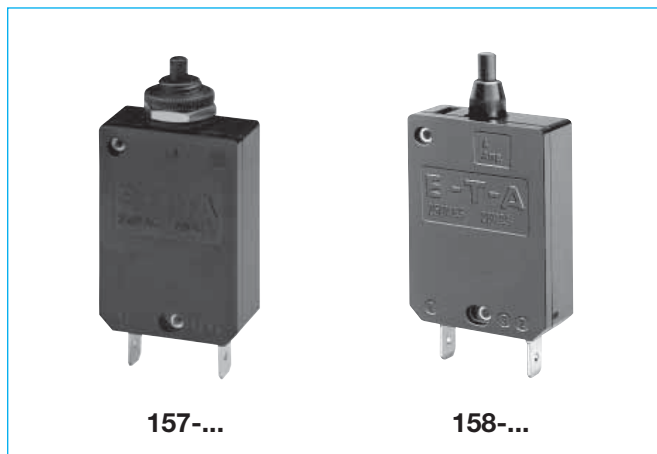

Technical data

For further details please see chapter: Technical Information

Voltage rating	AC 250 V; DC 28 V (UL: AC 250 V; DC 50 V)
Current ratings	0.05...25 A
Typical life	0.05...16 A 5,000 operations at 2 x I _N , inductive 17...25 A 5,000 operations at 2 x I _N , resistive
Ambient temperature	-20...+60 °C (-4...+140 °F)
Insulation co-ordination (IEC 60664 and 60664 A)	rated impulse withstand voltage 2.5 kV pollution degree 2 reinforced insulation in operating area
Dielectric strength (IEC 60664 and 60664A) operating area	test voltage AC 3,000 V
Insulation resistance	> 100 MΩ (DC 500 V)
Interrupting capacity I _{cn}	0.05...2.5 A 8 x I _N 3...5 A 20 x I _N 6...12 A 200 A 13...25 A 400 A
Interrupting capacity (UL 1077)	I _N 0.05...20 A U _N AC 250 V 2,000 A 0.05...25 A DC 50 V 2,500 A
Degree of protection (IEC 60529/DIN 40050)	operating area IP40 terminal area IP00
Vibration	8 g (57-500 Hz) ± 0.61 mm (10-57 Hz) to IEC 60068-2-6, test Fc, 10 frequency cycles/axis
Shock	25 g (11 ms) to IEC 60068-2-27, test Ea
Corrosion	96 hours at 5 % salt mist, to IEC 60068-2-11, test Ka
Humidity	240 hours at 95 % RH to IEC 60068-2-78, test Cab
Mass	approx. 24 g

Approvals

Authority	Voltage ratings	Current ratings
VDE (EN 60934)	AC 250 V; DC 28 V	0.05...25 A
CSA, UL	AC 250 V DC 50 V	0.05...20 A 0.05...25 A

Dimensions

157-P10

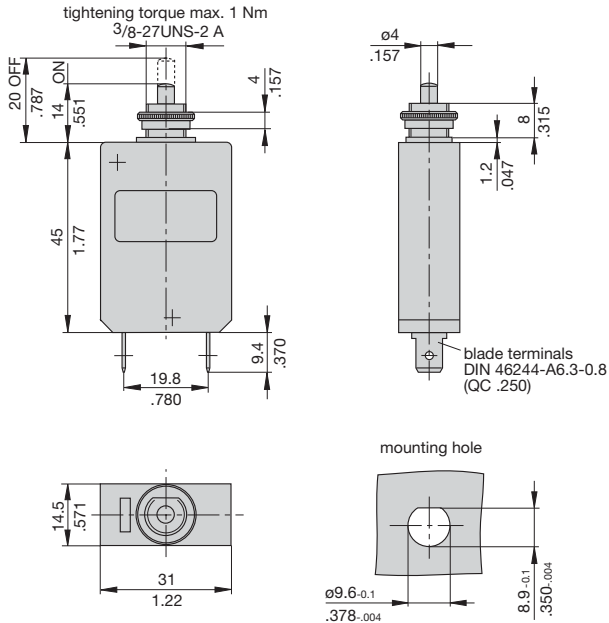

158-P10

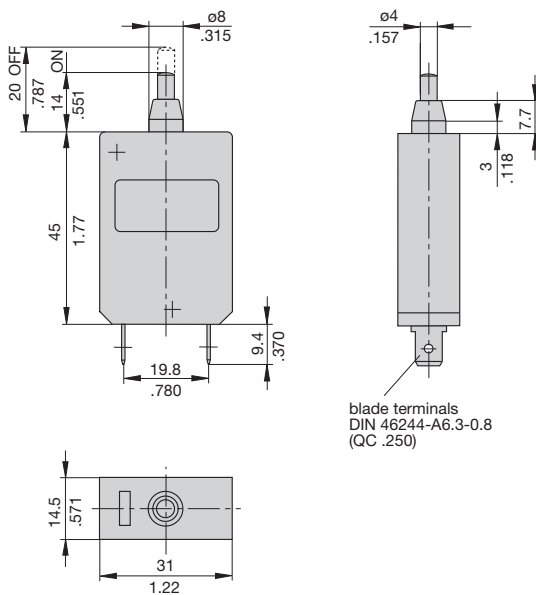

157/158-K10

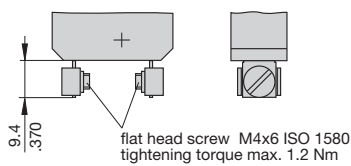

Internal connection diagram

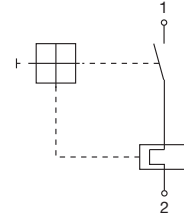

Typical time/current characteristics at +23 °C/+73.4 °F

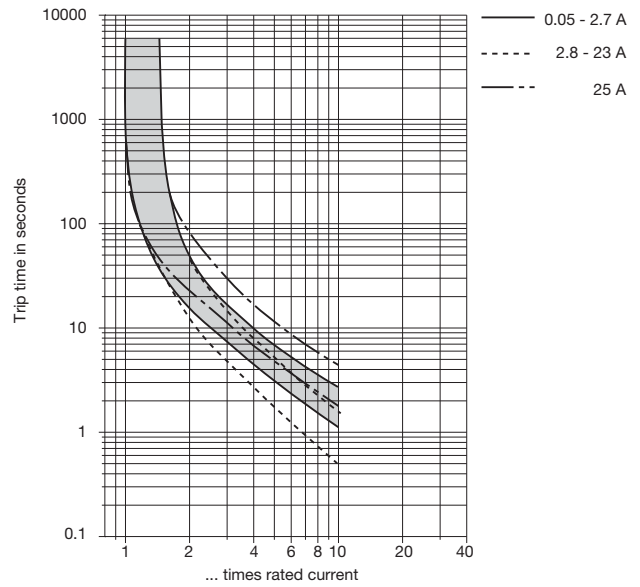

The time/current characteristic curve depends on the ambient temperature prevailing. In order to eliminate nuisance tripping, please multiply the circuit breaker current ratings by the derating factor shown below. See also section Technical information.

Ambient temperature °F	-4	+14	+32	+73.4	+104	+122	+140
°C	-20	-10	0	+23	+40	+50	+60
Derating factor	0.76	0.84	0.92	1	1.08	1.16	1.24

Installation drawings

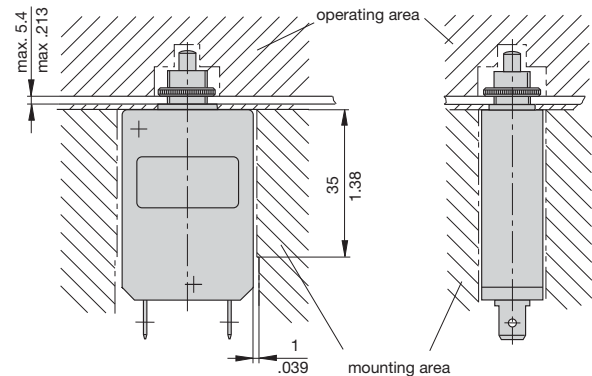

This is a metric design and millimeter dimensions take precedence (mm/ inch)

Accessories

Mounting sockets 10F-P10 (up to 16 A max. load)

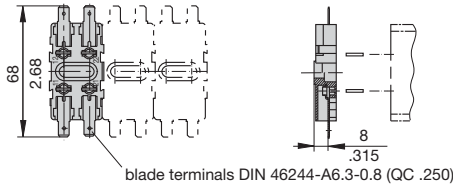

10F-K10 (up to 20 A max. load)

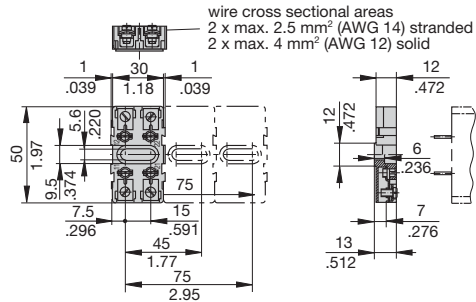

10F-A10 (up to 16 A max. load)

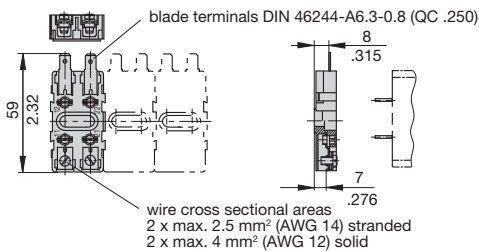

Accessories for sockets (up to 20 A max. load) 2-way bus bar Y 301 166 02 4-way bar Y 301 166 01

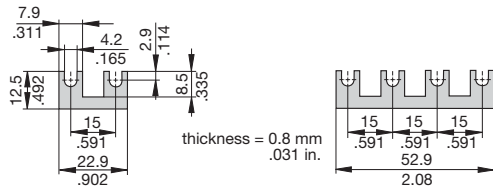

Connector bus links -K10

X 210 589 01/ 2.5 mm² (AWG 14), black (up to 20 A max. load)
X 210 589 02/ 1.5 mm² (AWG 16), brown (up to 13 A max. load)

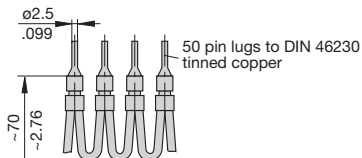

Connector bus links -P10

X 210 588 01/ 1.5 mm² (AWG 16), brown (up to 13 A max. load)
X 210 588 02/ 2.5 mm² (AWG 14), black (up to 20 A max. load)
X 210 588 03/ 2.5 mm² (AWG 14), red (up to 20 A max. load)
X 210 588 04/ 2.5 mm² (AWG 14), blue (up to 20 A max. load)

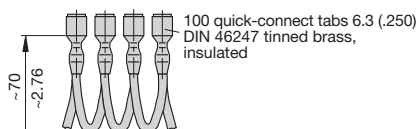

Accessories for type 157-...

Front panel water splash cover, transparent Y 300 538 01 and knurled nut Y 300 628 01 X 200 799 01 (bonded to nut) (IP64)

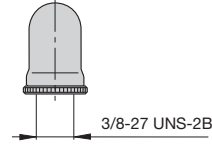

Front panel water splash cover, transparent with special knurled nut X 200 798 02 (bonded to nut) (IP64)

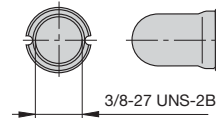

Splash cover (black) with hex nut (IP64) X 210 739 01

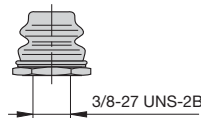

This is a metric design and millimeter dimensions take precedence ($\frac{\text{mm}}{\text{inch}}$)

All dimensions without tolerances are for reference only. In the interest of improved design, performance and cost effectiveness the right to make changes in these specifications without notice is reserved. Product markings may not be exactly as the ordering codes. Errors and omissions excepted.