

# Amphenol

## 62GB Miniature Bayonet 10-76 Connector Variant



The miniature bayonet connector series offers designers important features not found in any other range of connectors. They are developed and manufactured entirely in the U.K. 62GB connectors have been well established globally on both industrial military communication projects, including Europe, Canada and India.

- 10-76 has a plating finish of zinc cobalt olive drab.
  - This has a high resistance to corrosion and has been dictated on Bowman in the U.K.
- Shell size 10 throughout the connector range
- Contacts are gold plated and 10-76 planform consists only of 7 size 20 contacts and 6 size 22 contacts
- Operating temperature is  $-55^{\circ}\text{C}$  to  $125^{\circ}\text{C}$
- Shells are keyed to prevent mismatching between shells of different orientations
- Designation F is for Radio Audio, N for Data and E for Ethernet.
- Orientation N is for Data
- Other orientations available are B and C

The 10-76 series is designed specifically to be backward compatible with the Clansman 10-07 planform that has been in use over the last thirty years. It is specified on the Bowman radio system.

A 10-76 receptacle that has socket contacts will mate with a 10-07 plug that has pin contacts.

Technical Information

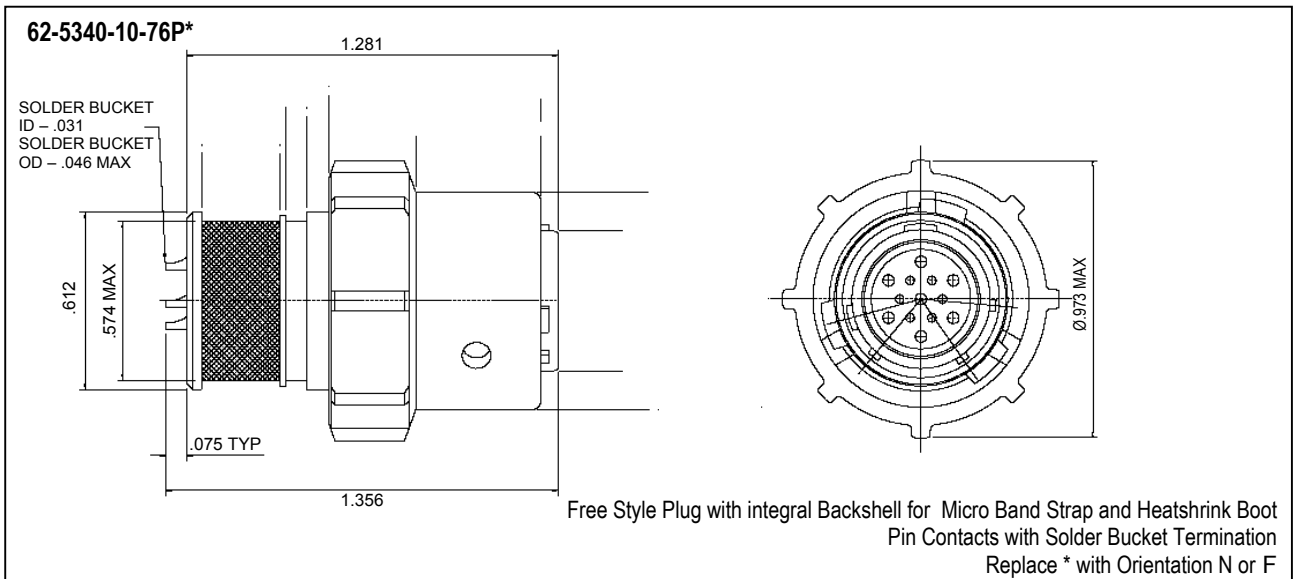
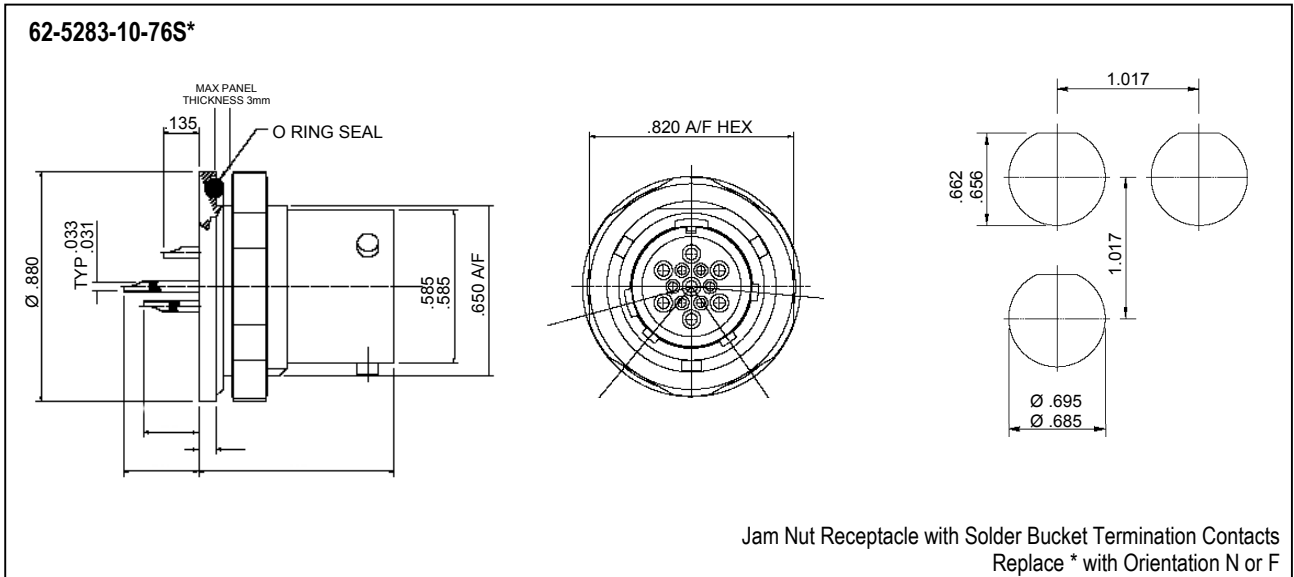
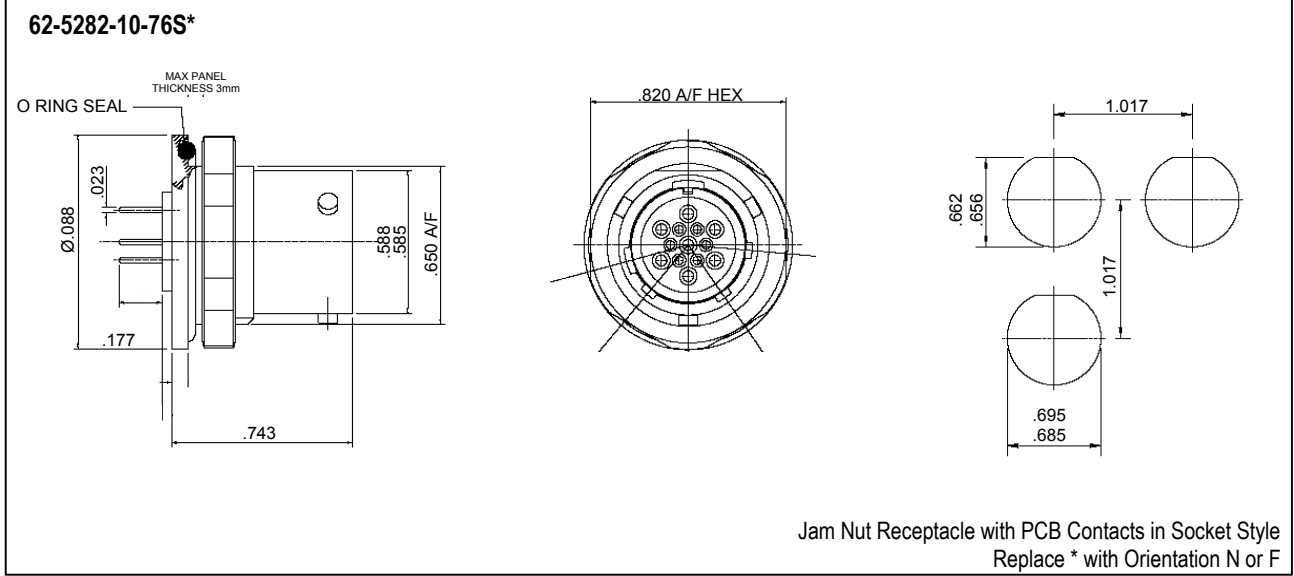

Technical Information

62-5338-10-76P\*

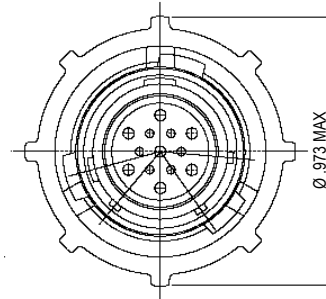
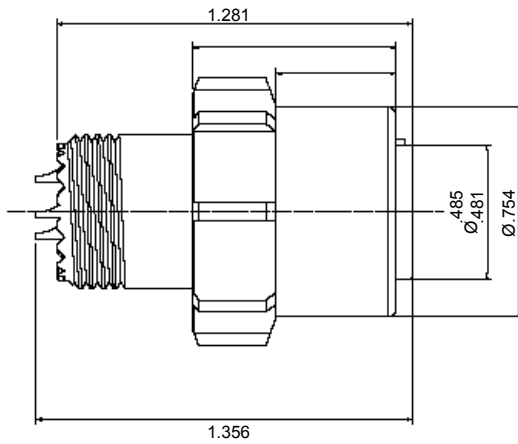

Free Style Plug with Thread to accept AIA 5001 range of Backshells  
Replace \* with Orientation N or F

AIA-5001-10-00-00-10-AA-04

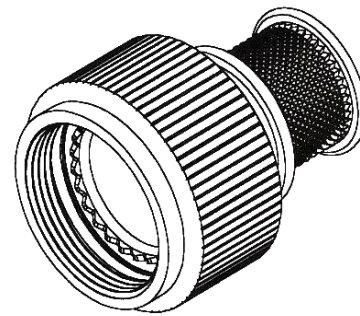
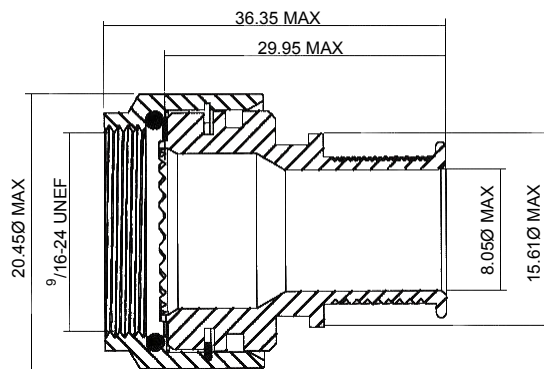

Straight Backshell to suit 62-5338-10-76P\*

AIA-5001-10-00-00-10-AA-04

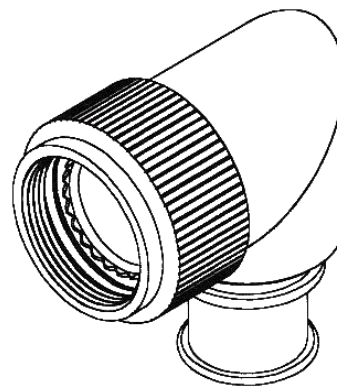
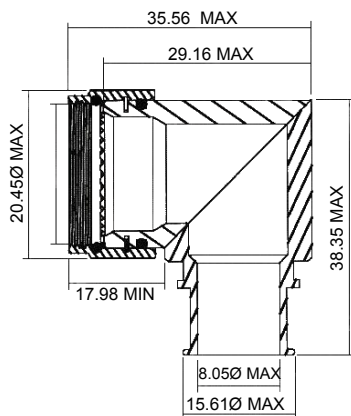

90° Backshell to suit 62-5338-10-76P\*

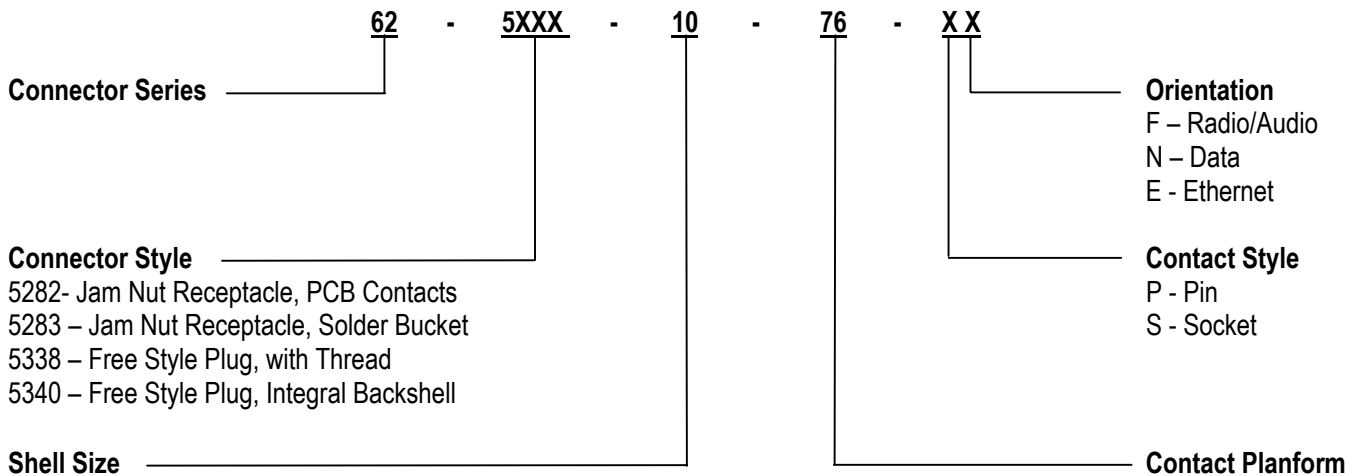
**Part Number Information****Connectors****Backshell – Straight**

- AIA-5001-10-00-00-10-AA-04
- HE 100 – Spring
- 608-107-14 – Band Strap
- 154-42-GW24 – Straight Heatshrink Boot

**Backshell – 90°**

- AIA-5001-10-00-00-90-AA-04
- HE 100 – Spring
- 608-107-14 – Band Strap
- 1154-4-GW24 – 90° Heatshrink Boot

Micro Band Strap for 62-5340 connector – 600-057

**Dust Caps**

- 62GB-813-10 – Receptacle Cap and Cord, Zinc Cobalt Olive Drab
- 62GB-810-10 – Plug Cap and Cord, Zinc Cobalt Olive Drab

Cadmium Olive Drab plate available on request.

For Dust Cap detail and alternative options, please see 62GB Accessory catalogue.

For Cable Assemblies, please consult factory.

**Notice:** Products are sold subject to Amphenol's conditions of sale ("the standard conditions"). All specifications and statements contained herein are believed to be correct at the time of printing but no representation or warranty, express or implied, is given as to any specification or statement contained herein. Product specifications including performance characteristics are typical only and subject to deviation. Specifications are also subject to change without notice. Users should not assume that all safety measures are indicated or that other measures may not be required. No representation or warranty, express or implied, is given that any use of products (including any stated or suggested use) does not infringe any patent, registered design or other third party rights and no stated or suggested use of products can be taken to recommend any such infringement.